

## /// Plug-in voltage monitoring railway relay with 4 C/O contacts

Rugged plug-in relays for extreme reliability, within long endurance applications and harsh environments

### CMVD4-U200

Customizable voltage monitoring, timer delay-on/off relay

Part of D-platform



#### Description

Plug-in electronic customizable voltage monitoring relay with optional delay-on and delay-off timer function and four change-over contacts. Fully customizable according customer's requirements concerning voltage monitoring type and timing diagram.

CMVD4 can provide multiple voltage thresholds (adjustable) for both pull-in and drop-out voltages with different timing delays. The relay can also be supplied with a fixed pull-in and drop-out voltage.

The delay times are also adjustable (either delay-on or delay-off, the other delay is fixed). The relay can also be supplied with symmetrical or asymmetrical flashing, 1-shot, 2-shot, 3-shot etc or with fixed time delays. A maximum of 3 parameters can be adjusted by means of 2 screws and 1 knob.

Suitable for monitoring DC voltages.

The CMVD4-U200 offers a very small hysteresis (difference between pull-in and drop-out voltage). The relay is equipped with one LED which indicates activation of the time delay (blinking light) and the status of the relay contacts (continuously ON or OFF). Delay-off function for voltage drop down to 50 % of minimum pull-in voltage, no auxiliary supply necessary.

Standard equipped with magnetic arc blow-out for high breaking capacity and long contact life.

The construction of the relay and choice of materials makes the CMVD4-U200 relay suitable to withstand low and high temperatures, shock & vibrating and dry to humid environments. No external retaining clip needed as integrated 'snap-lock' will hold relay into socket under all circumstances and mounting directions.

#### Features

- Customizable DC voltage monitoring relay with timer function
- Compact plug-in design
- 4 C/O contacts
- Multiple voltage thresholds for both pull-in and drop-out voltages, adjustable
- Also available with fixed voltages
- Very small hysteresis possible
- Time delay on any voltage thresholds
- Different customizable timing possible
- No auxiliary power supply necessary
- Also available with fixed time delays
- Time/pulse delay range: 0...60 s
- 1 LED for status indication
- Flat, square and silver plated relay pins for excellent socket connection
- Integrated snap lock
- Optional positive mechanical keying relay to socket

#### Connection diagram

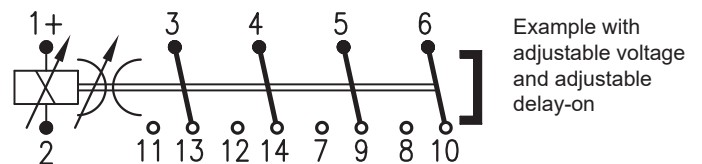

#### Timing diagram

See page 3.

#### Application

These relays are designed for demanding rolling stock applications. The CMVD4-U relay can be used in all railway applications where non-standard voltage monitoring and timer functions are necessary.

#### Railway compliancy

EN 50155	IEC 60947	EN 45545-2
IEC 60571	IEC 61373	NF F16-101/102
IEC 60077	EN 50121	NF F 62.002



## Voltage monitoring relay CMVD4-U200

### Options

- Gold plated contacts
- Extra dust protection (only for fixed voltage setting)
- AgSnO<sub>2</sub> contacts, high resistant to welding
- No magnetic arc blow-out
- Double make / double break contacts

Remark: Not all combinations possible

### Dimensions (mm)

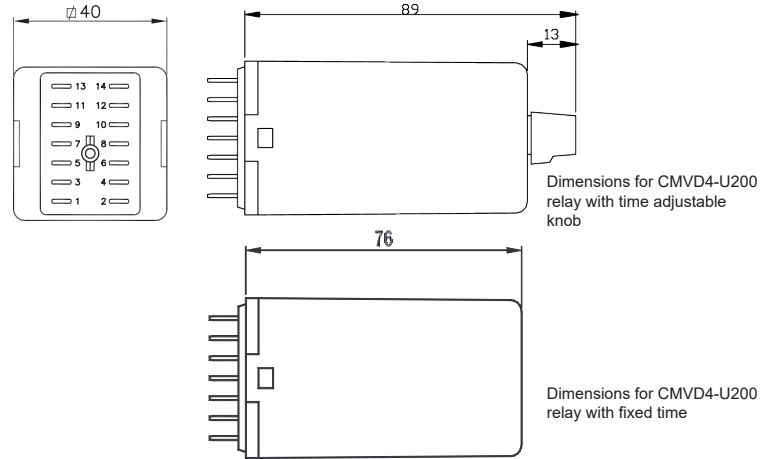

### Coil characteristics

Type	Drop-out Uadjustable (VDC)	Pull-in Uadjustable (VDC)	Current consumption (mA) monitoring only, relay switched off	Current consumption (mA) relay switched on
CMVD4-U201	15-60	20-60	2	21
CMVD4-U202	30-120	40-120	2.5	12
CMVD4-U204	45-180	60-180	3	9
CMVD4-U213	60-240	80-240	3.5	9
CMVD4-U215	75-300	100-300	4	8

Other types on request

Remark: Maximum adjustable voltage is also the maximum allowable voltage, otherwise the relay can be damaged.

**Example:** CMVD4-U204 with drop-out voltage 95 VDC and pull-in voltage 110 VDC and:

Application voltage (VDC)	Current consumption (mA)	Power (W)
30	3	0.1
90	3	0.3
100*	3	0.3
100**	9	0.9
120	9	1.1

\* Before relay has pulled in

\*\* After relay has pulled in

For more detailed technical specifications, drawings and ordering information, go to the product page on [www.morssmitt.com](http://www.morssmitt.com)

 **Over 10 million Mors Smitt relays in use in rail transport applications worldwide!**

**Mors Smitt Asia Ltd.**  
 26/F., Casey Aberdeen House  
 38 Heung Yip Road, Wong Chuk Hang  
 Hong Kong  
 Tel: +852 2343 555  
[sales.msa@wabtec.com](mailto:sales.msa@wabtec.com)

**Mors Smitt France SAS**  
 2 Rue de la Mandinière  
 72300 Sablé-sur-Sarthe, France  
 Tel: +33 (0) 243 92 82 00  
[sales.msf@wabtec.com](mailto:sales.msf@wabtec.com)

**Mors Smitt UK**  
 Graycar Business Park  
 Burton on Trent, DE13 8EN, UK  
 Tel: +44 (0)1283 357 263  
[sales.msuk@wabtec.com](mailto:sales.msuk@wabtec.com)

**Wabtec Netherlands B.V.**  
 Darwinstraat 10  
 6718 XR Ede, Netherlands  
 Tel: +31 (0)88 600 4500  
[sales.msbv@wabtec.com](mailto:sales.msbv@wabtec.com)

**Mors Smitt Technologies Ltd.**  
 1010 Johnson Drive  
 Buffalo Grove, IL 60089-6918, USA  
[salesmst@wabtec.com](mailto:salesmst@wabtec.com)

**RMS Mors Smitt**  
 19 Southern Court  
 Keysborough, VIC 3173, Australia  
 Tel: +61 (0)3 8544 1200  
[sales.rms@wabtec.com](mailto:sales.rms@wabtec.com)

(c) Copyright 2022

All rights reserved. Nothing from this edition may be multiplied, or made public in any form or manner, either electronically, mechanically, by photocopying, recording, or in any manner, without prior written consent from Mors Smitt. This also applies to accompanying drawings and diagrams. Due to a policy of continuous development Mors Smitt reserves the right to alter the equipment specification and description outlined in this datasheet without prior notice and no part of this publication shall be deemed to be part of any contract for the equipment unless specifically referred to as an inclusion within such contract. Mors Smitt does not warrant that any of the information contained herein is complete, accurate, free from potential errors, or fit for any particular purpose. Mors Smitt does not accept any responsibility arising from any party's use of the information in this document.

## Voltage monitoring relay CMVD4-U200

### Timing diagrams

Example 1:

Voltage monitoring relay is activated at  $U_{pull-in1}$  (threshold 1) with a delay-on  $T_{on1}$ . If the voltage is higher than  $U_{pull-in2}$  (threshold 2), the relay will switch on instantaneously.

The relay will drop out at  $U_{drop-out}$ . The first time with delay-off  $T_{off1}$ , the second time with delay-off  $T_{off2}$ . Then the cycle starts over again.

When the voltage drops down to 50% of the minimum pull-in voltage, the relays always drops-out instantaneously.

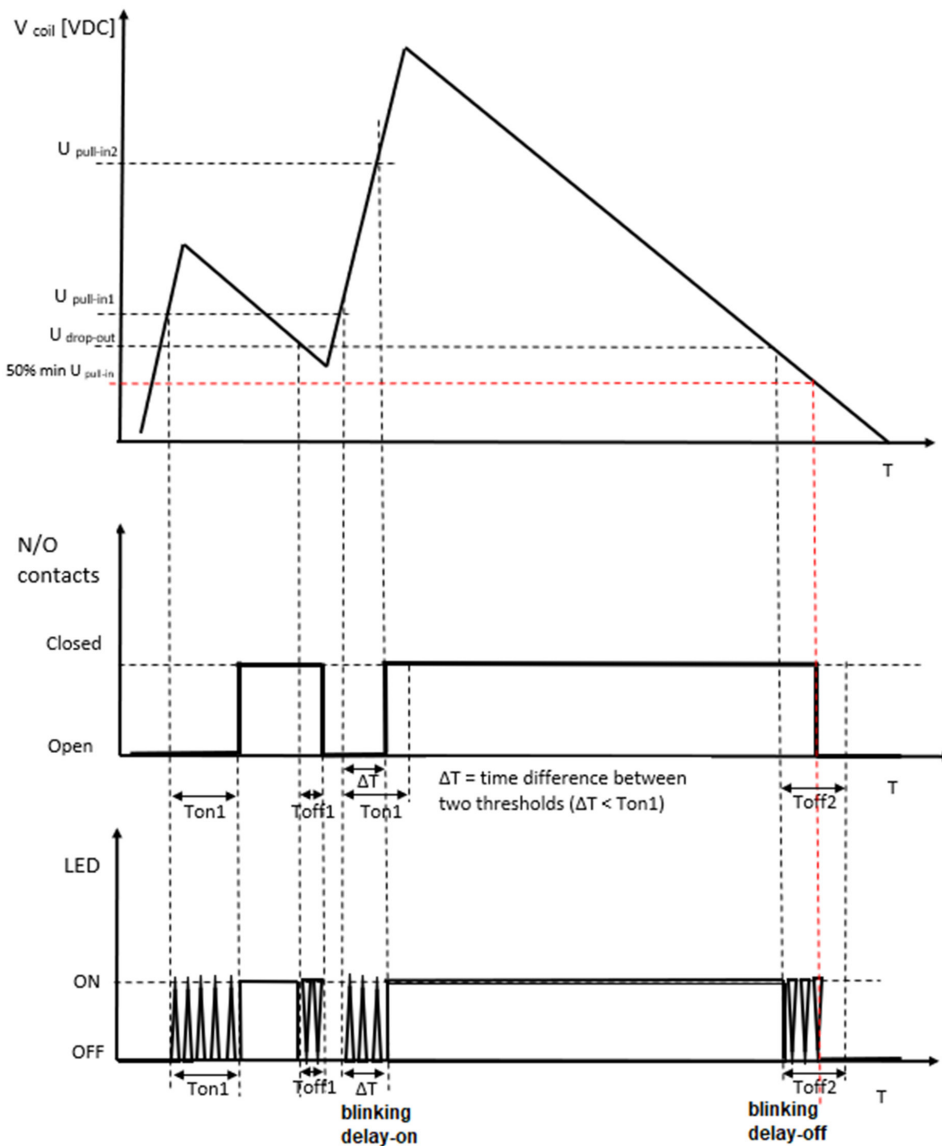

Timing diagrams presented are examples.  
Different configurations possible.

## Voltage monitoring relay CMVD4-U200

### Timing diagrams

Example 2.

Voltage monitoring relay is activated at  $U_{pull-in1}$  (threshold 1) with symmetrical flashing ( $T_1$ ). If the voltage is higher than  $U_{pull-in2}$  (threshold 2), the relay will switch with symmetrical flashing ( $T_2$ ).

The relay will drop out at  $U_{drop-out}$  without time delay.

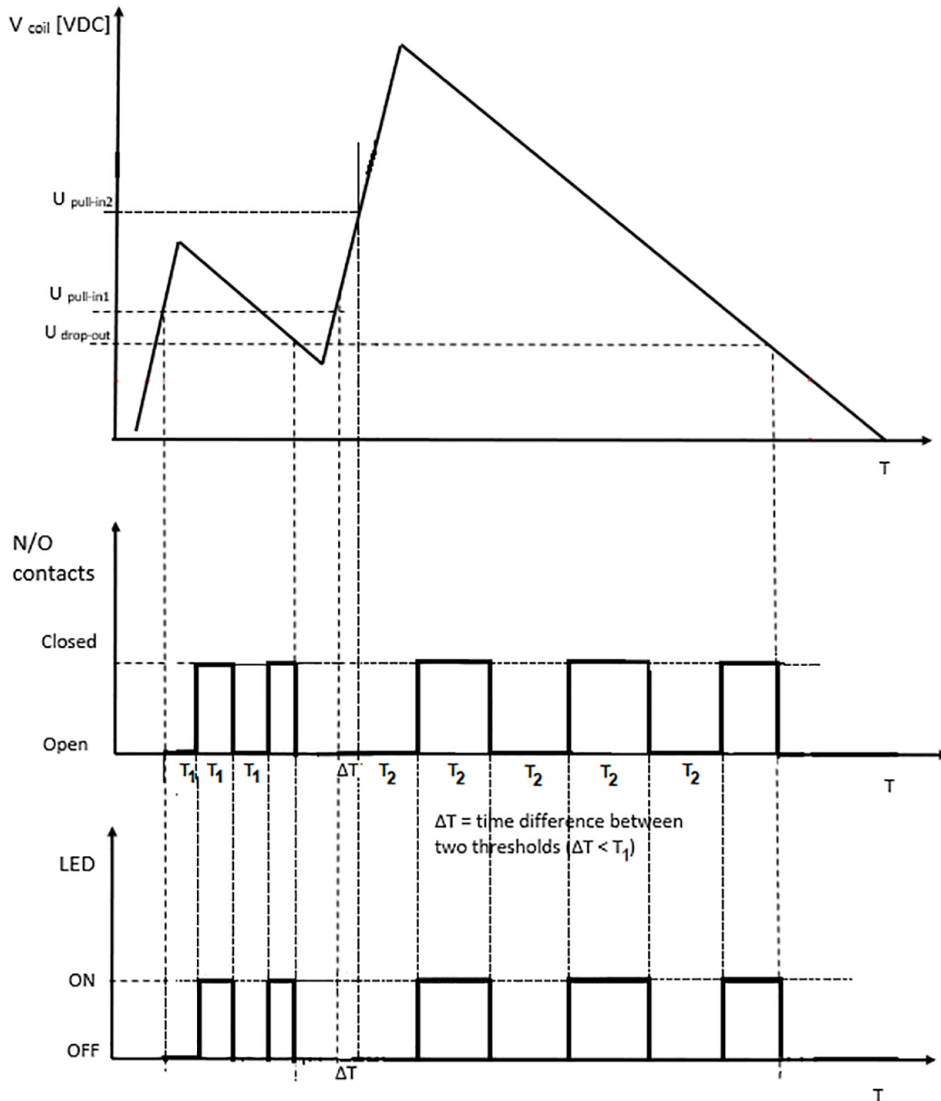

Timing diagrams presented are examples.  
Different configurations possible.

## Voltage monitoring relay CMVD4-U200

### Timing diagrams

Example 3:

At pull-in1 the N/O contacts will close as per pulse T1. If the voltage increases to pull-in2 pulse2 will overwrite pulse1. The length of the second pulse will be T2.

- If during pulse T1 or T2 the voltage drops below the pull-in voltage, the pulse remains.
- If during pulse T1 or T2 the voltage drops below the pull-in voltage but not below the drop-out voltage, and increases to the pull-in voltage within the pulse time, only the initial pulse remains.
- If during pulse T1 or T2 the voltage drops below the drop-out voltage, the relay will drop-out instantaneously and the relay is reset to the initial state.

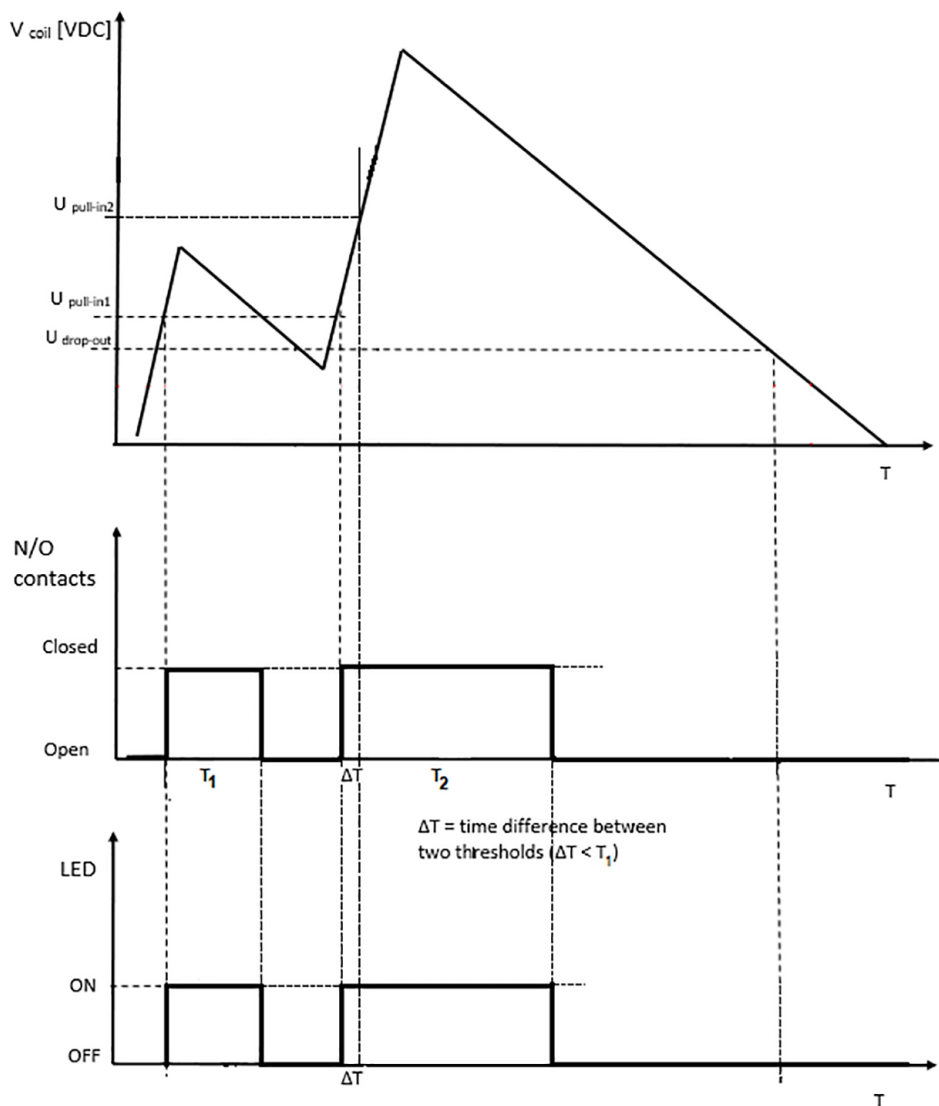

Timing diagrams presented are examples.  
Different configurations possible.

## Voltage monitoring relay CMVD4-U200

### Timing diagrams

Example 4:

At pull-in 1 the contacts will close as per pulse T1. If the voltage increases to pull-in2 symmetrical flashing starts with T2, which overwrites pulse 1.

- If during pulse T1 or T2 the voltage drops below the pull-in voltage, the pulse remains.
- If during pulse T1 or T2 the voltage drops below the pull-in voltage but not below the drop-out voltage, and increases to the pull-in voltage within the pulse time, only the initial pulse T1 or flashing pulse T2 remains.
- If during pulse T1 or T2 the voltage drops below the drop-out voltage, the relay will drop-out instantaneously and the relay is reset to the initial state.

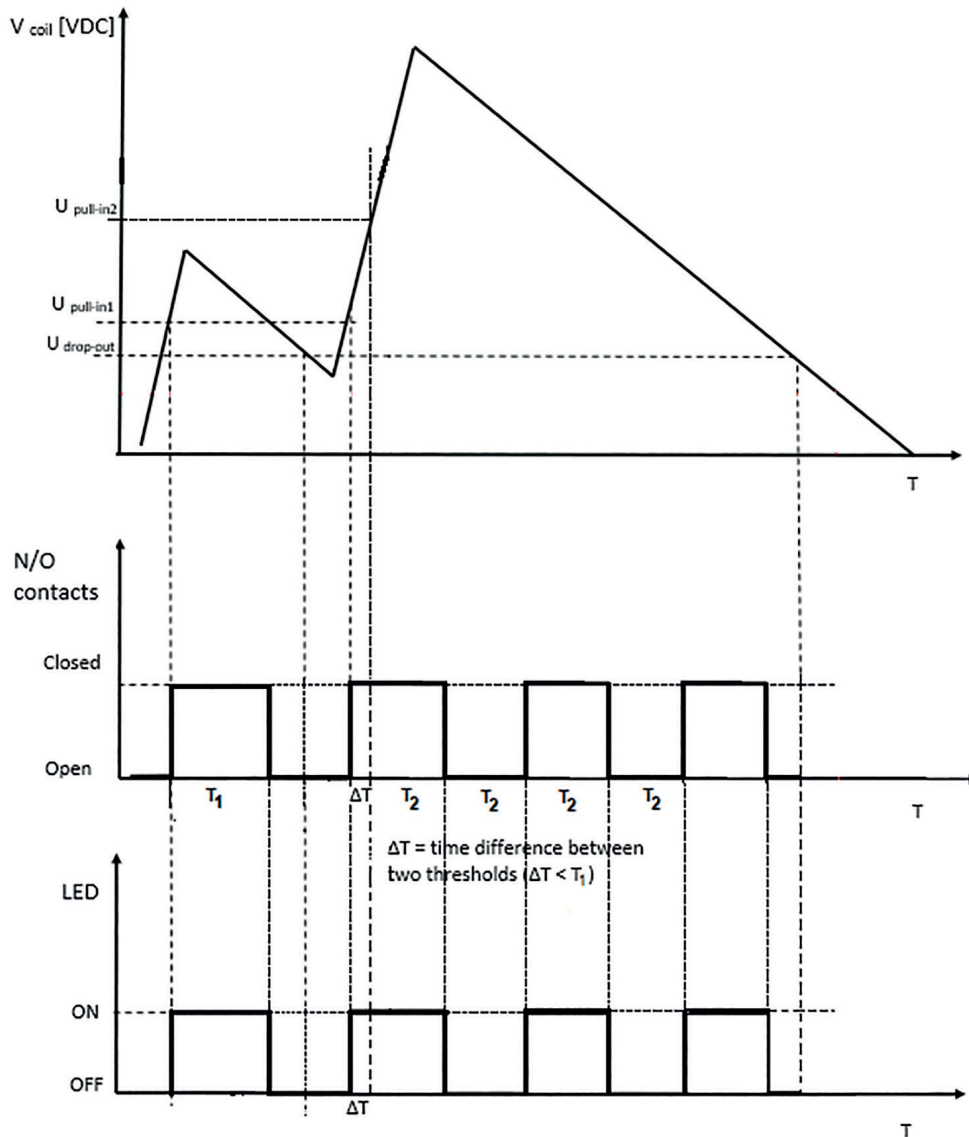

Timing diagrams presented are examples.  
Different configurations possible.

## Voltage monitoring relay CMVD4-U200

### Technical specifications

The hardware of CMVD4-U200 is the same as MTDV4-U200 relay. The difference consists in a different firmware customized for each special application.

### Voltage characteristics

Voltage settings	Drop-out and pull-in both adjustable, or both fixed value. Multiple thresholds possible.	
Minimal hysteresis	2 % x U <sub>pull-in</sub>	
Accuracy	Fixed voltages	Max. ± 0.25 % deviation
	Repeatability	Max. ± 0.5 % deviation
	Temperature variation	Max. ± 0.02 % / degree (compared to 20 °C)
<b>Example</b> Pull-in voltage set on 110.0 VDC. The ambient temperature is 40 °C which is 20 degrees different compared to the standard 20 °C. This results in 0.4 % extra voltage variation. The total maximum voltage variation is then 0.5 % (due to repeatability) + 0.4 % (due to temperature) = 0.9 %. In this case every pull-in voltage will be between 109.0 and 111.0 VDC.		

### Contact characteristics

Amount and type of contacts	4 C/O	
Peak inrush current	NF F 62-002	200 A (withstand > 10 x 200 A @ 10 ms, 1 min) 80 A (withstand > 10 x 80 A @ 200 ms, 1 min) 40 A (withstand > 10 x 40 A @ 500 ms, 1 min) 30 A (withstand > 10 x 30 A @ 1000 ms, 1 min)
Maximum continuous current	8 A	
Maximum switching voltage	250 VDC, 440 VAC	
Minimum switching voltage	12 V	
Minimum switching current	10 mA	
Maximum breaking capacity	110 VDC, 8 A (L/R ≤ 15 ms) 230 VAC, 10 A (cos φ ≥ 0.7)	
Contact resistance	15 mΩ (initial)	
Material	Ag standard (optional AgSnO <sub>2</sub> , Au on Ag)	
Contact gap	0.7 mm	
Contact force	> 200 mN	

### Electrical characteristics

Dielectric strength	Pole-pole	4 kV, 50 Hz, 1 min
	Cont-coil	2.5 kV, 50 Hz, 1 min
	Open contacts	2.5 kV; 50 Hz; 1 min
Pulse withstanding	IEC 60255-5	5 kV (1.2/50 μs)
EMC	EN 50121-3-2	Compliant

### Mechanical characteristics

Mechanical life	1 x 10 <sup>6</sup> operations	
Maximum switching frequency	Mechanical: 3600 ops/h Electrical: 1200 ops/h	
Torque value screw to lock knob	02-0.4 Nm	
Weight	190 g (with adjustable knob)	

## Voltage monitoring relay CMVD4-U200

### Environmental characteristics

Environmental	EN 50125-1
Vibration	IEC 61373, Category I, Class B, Body mounted
Shock	IEC 61373, Category I, Class B, Body mounted
Operating temperature	-40 °C...+70 °C
Humidity	93%
Maximum altitude	2000 meter. Higher altitudes are possible but have consequences mentioned in IEC 60664 (for example 5000 meter with bigger clearance distance)
Salt mist	IEC 60068-2-11, class ST4
Damp heat	IEC 60068-2-30, Test method Db variant 1
Protection	IEC 60529, IP40 (relay on socket) (with option K: IP50)
Fire & smoke	NF F 16-101, NF F 16-102, EN 45545-2: HL3 for requirements R22, R23, R26
Insulation materials	Cover: polycarbonate Base: polyester

### Railway compliancy

EN 50155	Railway applications - Rolling stock - Electronic equipment
IEC 60571	Railway applications - Electronic equipment used on rolling stock
IEC 60077	Railway applications - Electric equipment for rolling stock
IEC 60947	Low-voltage switchgear and controlgear
IEC 61373	Railway applications - Rolling stock equipment - Shock and vibration tests
EN 50121	Railway applications - Electromagnetic compatibility
NF F16-101/102	Railway rolling stock - Fire behavior
EN 45545-2	Railway applications - Fire protection on railway vehicles Part 2: Requirements for fire behavior of materials and components
NF F 62-002	Railway rolling stock - On-off contact relays and fixed connections

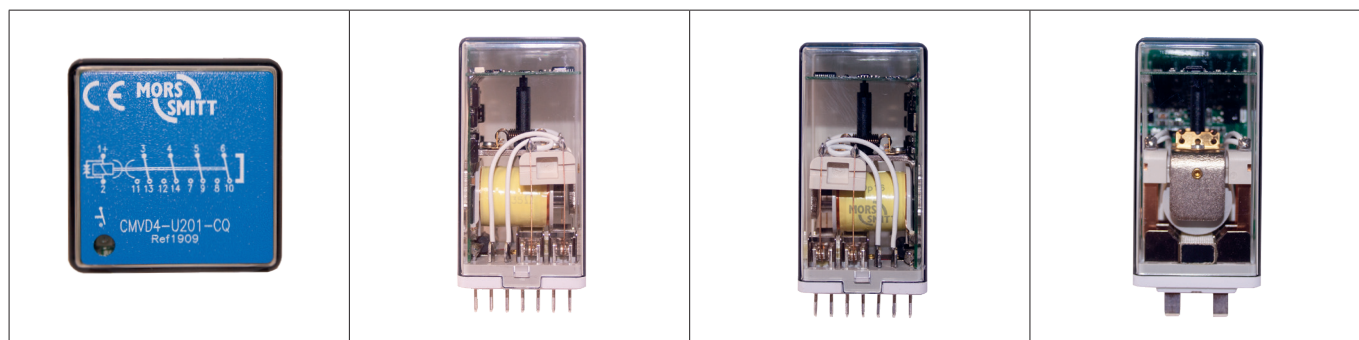



## Voltage monitoring relay

### CMVD4-U200

### Options

Code	Description	Remark	Cannot be combined with:
------	-------------	--------	--------------------------

#### Standard options:

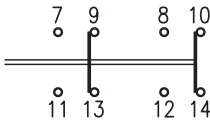
E*	Au; Gold plated contacts (10 µm)		M
K	Extra dust protection	Only for fixed voltage settings. IP50 Cat 2 for the relays mounted in a Mors Smitt socket. Application PD1/PD2 and contact load > 0.5 A.	
N	No magnetic arc blow-out		
Y	Double make/double break contacts	2 C/O DM/DB 	
Keying	Coil coding relay and socket	For details see page 9	

#### Special options:

M	AgSnO <sub>2</sub> ; "non-weldable" contacts	Icontact > 100 mA	E
---	--	-------------------	---

#### \* Gold plated contacts characteristics

Material	Ag, 10 µm gold plated
Maximum switching voltage	60 V (higher voltages may be possible, contact Mors Smitt for more information)
Maximum switching current	400 mA (at higher rate gold will evaporate, then the standard silver contact rating of minimum 10 mA and 12 V is valid)
Minimum switching voltage	5 V
Minimum switching current	1 mA

Remark: For application support or technical product support, contact your local Mors Smitt sales office (see contact details on last page).

## Voltage monitoring relay CMVD4-U200

### Electrical life expectancy

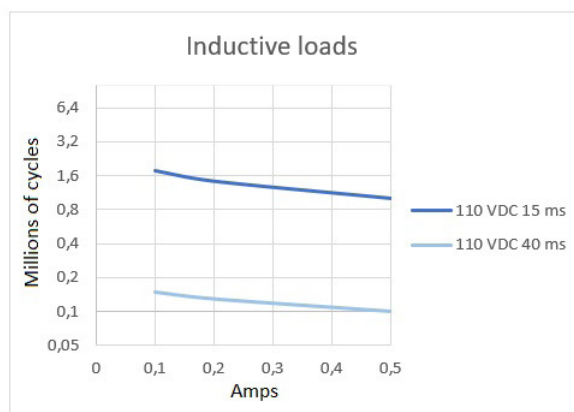
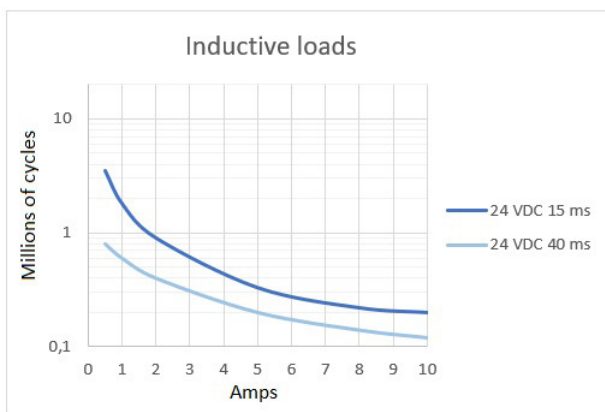
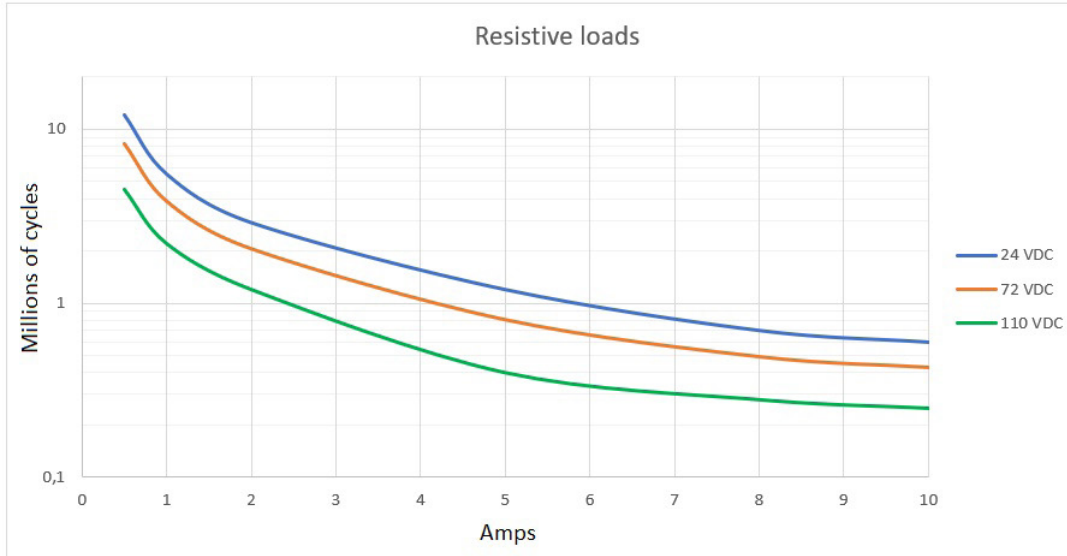

By connecting 2 contacts in series the DC current breaking capacity is increased by 50 %. Electrical lifetime is tested under laboratory conditions with switching frequency 0.33 Hz.

Note: The actual electrical lifetime in the application is affected by the switching frequency, type of contact (N/O or N/C), environmental conditions, etc.

For highly inductive loads Mors Smitt A400/B400 relays with standard double make double break contacts are the optimal solution.

### Self-cleaning contacts

Each contact attracts organic molecules. When the surface is loaded with a voltage, like a relay contact, the attracting force is even higher. Therefore on each contact surface there is organic "pollution".

Mors Smitt relays are designed to clean itself during switching of the contacts:

1. Mechanical wiping action: the "pollution" is swept aside.  
The movement of opposing contacts when they make contact: this wiping action cleans the surface of both contacts. Mors Smitt relays are designed for optimal wiping action: enough to clean the surface and not too much to prevent contact wear.
2. Electrical cleaning: the "pollution" is burnt away.  
A current at sufficient level will evaporate organic "pollution". When switching loads (typically of a current >100 mA), the "pollution" is totally burnt away and a clean contact surface is available.

The result is a good contact between two opposing contacts without interference due to polluted contacts.

## Voltage monitoring relay CMVD4-U200

### Mounting possibilities/sockets



#### Surface/wall mounting

338000302	V22BR	Screw socket, wall mount, front connection (9 mm terminals)
338000580	V23	Screw socket, wall mount, front connection (7.5 mm terminals)
338000610	V29	Spring clamp socket, wall mount, front dual connection (2.5 mm <sup>2</sup> )

#### Rail mounting

338000580	V23	Screw socket, rail mount, front connection (7.5 mm terminals)
338000402	V23BR	Screw socket, rail mount, front connection (9 mm terminals)
338000610	V29	Spring clamp socket, rail mount, front dual connection (2.5 mm <sup>2</sup> )

#### Panel/flush mounting

338100100	V3	Solder tag socket, panel mount, rear connection
328400100	V26	Crimp contact socket, panel mount, rear connection, A260 crimp contact
338000560	V31	Faston connection socket, rear dual connection (4.8 x 0.8 mm)
338000670	V33	Push-in terminal socket, panel mount, rear dual connection (3.3 mm <sup>2</sup> )

#### PCB mounting

338000561	V32	PCB soldering socket
-----------	-----	----------------------

No external retaining clip needed as the 'snap-lock' will hold the relay into the socket under all circumstances and mounting directions (according shock & vibration requirements IEC 61373, Category I, Class B, Body mounted). If regulations require external retaining clips, these are available as well.

For more details see datasheets of the sockets on [www.morssmitt.com](http://www.morssmitt.com)

## Voltage monitoring relay CMVD4-U200

### Mechanical keying relay and socket (optional)

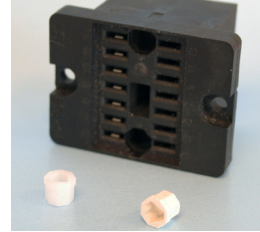

Function:

- To prevent wrong installation
- To prevent damage to equipment
- To prevent unsafe situations

Using keyed relays and sockets prevents a relay is inserted in a wrong socket. For example it prevents that a 24 VDC relay is put in a 110 VDC circuit. Positive discrimination is possible per different function, coil voltage, timing, monitoring, safety and non-safety.

The D relay socket keying option gives  $8 \times 8 = 64$  possibilities. Upon ordering the customer simply indicates the need for the optional keying. Mors Smitt will assign a code to the relay and fix the pins into the relay. The sockets are supplied with loose key receptacles. Inserting the keys into the socket is very simple and self explaining.

Remark: Sockets and relay shown are examples.

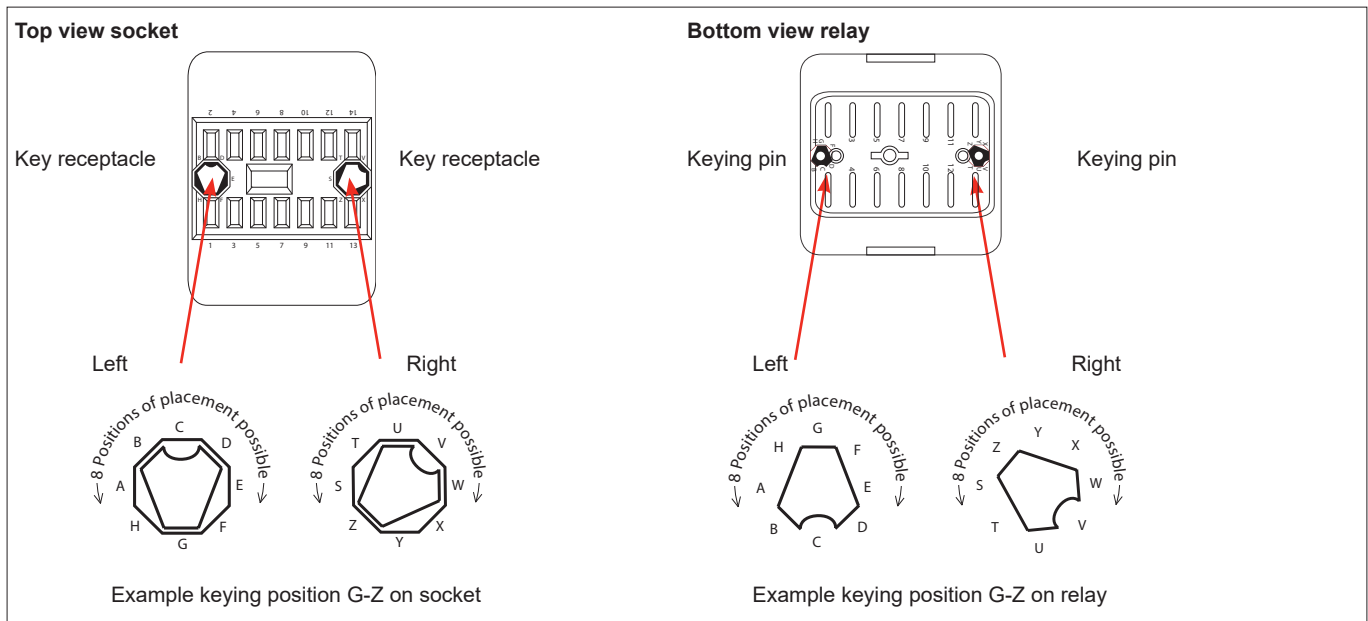

### Keying codes

	Coil voltage code				
	U201	U202	U204	U213	U215
Silver contacts (standard)	AS	AT	AV	AX	AY
Gold contacts (option E)	DT	HU	HV	HX	HY
Silver tin oxide (option M)	GT	GU	GW	GX	GY

## Voltage monitoring relay CMVD4-U200

### Important for relay selection and operation

Make sure the relay is suitable for the application. For critical applications (for example: green loop applications) relays should be checked on correct working during periodic inspection.

### Recommendations for long time contact reliability

For relays to enable failure free performance over a very long operational time, it is important to create the right circumstances. In any relay, contact usage and atmospheric conditions influence the contact surface. To counter this effect it is common practice to use a safety factor of  $> 2$  to ensure long time contact reliability.

Therefore for long time contact reliability we recommend:

- Silver contacts: a minimum contact current of 20 mA per contact
- Gold contacts: a minimum contact current of 10 mA per contact
- Double Make Double Break contacts: a minimum contact current of 40 mA per contact
- When low currents are switched and not frequently, e.g. 10 mA once a day, it is advised next to gold plated contacts to put similar contacts within the same relay in parallel
- With higher load switching, e.g. 110 VDC and  $> 1$  A, put relay contacts in series
- Rule of thumb: any relay works best with switching currents  $> 20$  mA in DC environment when frequently switched. When not switched frequently a higher switching current like 50 mA is better for a long reliable operational time
- Check relays regularly, for example with the Mors Smitt Portable Relay Tester and visually through the transparent cover

### Instructions for use

#### Installation

Before installation or working on the relay: disconnect the power supply first (no hot swapping)! Install socket and connect wiring according to the terminal identification. Plug relay into the socket ensuring there is no gap between the bottom of relay and the socket. Reverse installation into the socket is not possible due to the mechanical blocking snap-lock feature. Check to ensure that the coil connection polarity is not reversed. Relays can be mounted tightly together to save space. When rail mounting is used, always mount the socket in the direction of the UP arrow, to have proper fixation of the socket on the rail. Torque value screw to lock knob: 0.2-0.4 Nm.

#### Warning!

- Never use silicon in the proximity of the relays
- Do not use the relay in the presense of flammable gas as the arc generated from switching could cause ignition
- To remove relays from the socket, employ up and down lever movements. Sideway movement may cause damage to the coil wires

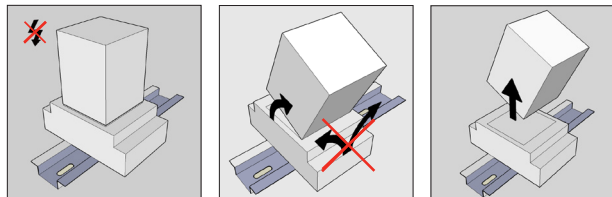

- Relays should never be swapped to other circuit positions when taken out of its socket for inspection or fault finding, always place it back into the original position to prevent contact resistance problems. Contact resistance problems can be created when swapping relays between different circuit loads due the contact wear/condition having changed during its operational life.

#### Operation

After installation always apply the rated voltage to the coil to check correct operation. Long term storage may corrode the silver on the relay pins. When plugging the relay into the socket, the female bifurcated or trifurcated receivers will automatically cut through the corrosion on the pins and guarantee a reliable connection.

Before actual use of relays, it is advised to switch the load several times with the contacts. The contacts will both be electrically and mechanically cleaned due to the positive wiping action. Sometimes a contact can build up increased contact resistance ( $\leq 15$  m $\Omega$  when new). When using silver contacts one can clean the contact by switching a contact load a few times using  $>24$  VDC &  $\sim 2$  A. Increased contact resistance is not always problematic, as it depends on circuit conditions. In general a contact resistance of 1  $\Omega$  is no problem, consult Mors Smitt for more information.

Condensation in the relay is possible when the coil is energised (warm) and the outside, environmental temperature is cold. This is a normal phenomenon and will not affect the function of the relay. Materials in the relay have no hygroscopic properties.

## Voltage monitoring relay CMVD4-U200

### Inspection / maintenance

Correct operation of the relay can easily be checked as the transparent cover provides good visibility of the moving contacts. If the relay does not seem to operate correctly, check for presence of the appropriate coil voltage and polarity using a suitable multimeter. If a LED is fitted, it indicates voltage presence to the coil. If coil voltage is present, but the relay does not operate, a short circuit of the suppression diode is possible (This may have been reversed due to the coil connection).

Relays can easily be tested with the Mors Smitt Relay Tester. More information on: [www.morssmitt.com](http://www.morssmitt.com).

If the relay doesn't work after inspection, replace the relay unit with a similar model. Do not attempt to open the relay cover or try to repair. Contacts are calibrated and in balance, touching can affect proper operation. Also resoldering may affect correct operation. Since 2009 relays have tamper proof seals fitted and once broken, warranty is void.

Most relay defects are caused by installation faults such as overvoltage, spikes/transients, high/short current far exceeding the relay specifications. When returning the relays for investigation, please provide all information on the RMA form. Send defective relays back to the manufacturer for repair or replacement. Normal wear and tear or external causes are excluded from warranty.

RMA procedure see [www.morssmitt.com](http://www.morssmitt.com)

## Voltage monitoring relay

### CMVD4-U200

#### Ordering scheme

CMVD4-U2		-	C		Ref		
Coil voltages	01					Drop-out 15-60 VDC, pull-in 20-60 VDC	
	02					Drop-out 30-120 VDC, pull-in 40-120 VDC	
	04					Drop-out 45-180 VDC, pull-in 60-180 VDC	
	13					Drop-out 60-240 VDC, pull-in 80-240 VDC	
	15					Drop-out 75-300 VDC, pull-in 100-300 VDC	
Options (add as many options as needed)			C			Low temperature (-40 °C) (Standard)	
			E			Gold plated contacts	M
			K			Extra dust protection, IP50	
			N			No magnetic arc blow-out	
			Y			Double make/ double break	
Special options (minimum order quantity: 20)			M			AgSnO <sub>2</sub> contacts, highly resistant to welding	E
	Reference to specific requirements				Ref xxxx	Customer specific configuration	

Example: CMVD4-U204-CE Ref 2018

Description: CMVD4-U200 relay, Drop-out 45-180 VDC, pull-in 60-180 VDC, low temperature (-40 °C), gold plated contacts, reference 2018

**Voltage monitoring relay**  
**CMVD4-U200**

---

 **Over 10 million Mors Smitt relays in use in rail transport applications worldwide!**

**Mors Smitt Asia Ltd.**  
26/F., Casey Aberdeen House  
38 Heung Yip Road, Wong Chuk Hang  
Hong Kong  
Tel: +852 2343 555  
sales.msa@wabtec.com

**Mors Smitt France SAS**  
2 Rue de la Mandinière  
72300 Sablé-sur-Sarthe, France  
Tel: +33 (0) 243 92 82 00  
sales.msf@wabtec.com

**Mors Smitt UK**  
Graycar Business Park  
Burton on Trent, DE13 8EN, UK  
Tel: +44 (0)1283 357 263  
sales.msuk@wabtec.com

**Wabtec Netherlands B.V.**  
Darwinstraat 10  
6718 XR Ede, Netherlands  
Tel: +31 (0)88 600 4500  
sales.msbv@wabtec.com

**Mors Smitt Technologies Ltd.**  
1010 Johnson Drive  
Buffalo Grove, IL 60089-6918, USA  
salesmst@wabtec.com

**RMS Mors Smitt**  
19 Southern Court  
Keysborough, VIC 3173, Australia  
Tel: +61 (0)3 8544 1200  
sales.rms@wabtec.com

(c) Copyright 2022

All rights reserved. Nothing from this edition may be multiplied, or made public in any form or manner, either electronically, mechanically, by photocopying, recording, or in any manner, without prior written consent from Mors Smitt. This also applies to accompanying drawings and diagrams. Due to a policy of continuous development Mors Smitt reserves the right to alter the equipment specification and description outlined in this datasheet without prior notice and no part of this publication shall be deemed to be part of any contract for the equipment unless specifically referred to as an inclusion within such contract. Mors Smitt does not warrant that any of the information contained herein is complete, accurate, free from potential errors, or fit for any particular purpose. Mors Smitt does not accept any responsibility arising from any party's use of the information in this document.