

## Features

- Improve security of sensitive, high speed digital status inputs
- Provides capacitor discharge protection for solid state status inputs to ENA TS 48-4
- Transient noise withstand to IEC60255 standards
- Compact and easy to fit and retrofit
- Instantaneous burden turn-on with ~50ms fixed dwell time
- Wide voltage operating range
- Thermal cut out protection
- Operation check LED
- Status input pick-up LED
- M4 screw terminals or optional flying leads
- ABMZ version with minimum voltage pick-up threshold and optional time delay

## Application

The ABM Active Burden Module is designed for application with solid state status inputs wherever high security signaling is required.

The ABM is intended to be used with digital relays and related products such as RTU's as an aid to improve electrical transient and noise immunity. In particular, for added immunity against infrequent and irregular transients such as represented by the capacitor discharge test as defined in standard ENA TS 48-4.

In normal operation, the ABM imposes a short term increased burden to the operate signal which is then removed after ~50 ms.

It is essential that devices that the ABM module is intended to be used with are specifically designed and purpose built for power industry and substation applications and already incorporate industry standard filtering, input loading and threshold setting capabilities.

The ABMZ version is a special version that provides a minimum voltage pick-up threshold. An optional time delay is available for application with fast acting inputs such as reed repeat relay circuits.

'Screw terminals' and 'Flying lead' type versions are available.

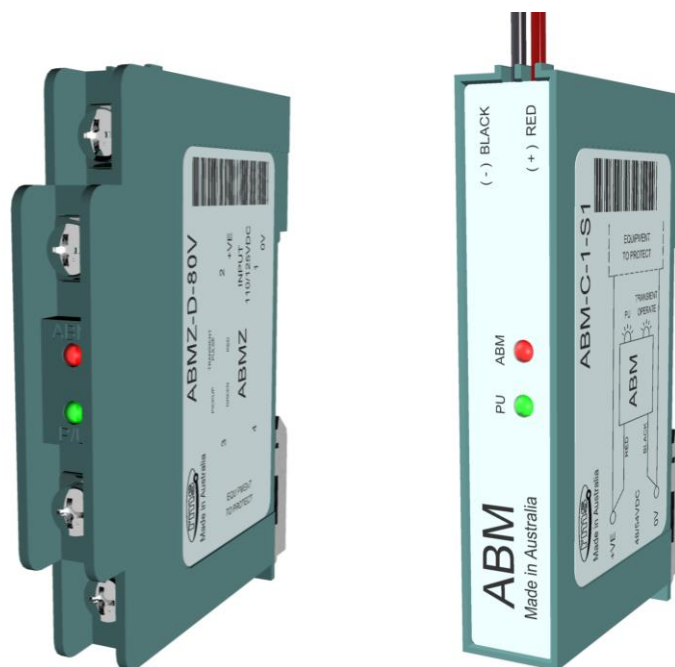

ABM Active Burden Modules  
(‘Screw terminal’ and ‘Flying lead’ versions depicted)

## Description

Made in Australia

Binary status inputs are employed extensively in power protection and control schemes for signaling a range of system events. For example:

- ◆ Direct trip to input commands e.g. Buchholz;
- ◆ Global enable or disable function;
- ◆ Blocking specific protection elements;
- ◆ Initiate timing or logical functions;
- ◆ Change protection setting groups;
- ◆ Maintaining status of secondary equipment circuits such as CB open / close;
- ◆ Reset of flag indicators.

The reliability of these inputs is critical to avoid false operation due to voltage fluctuations under transient conditions.

The interface between different devices has historically been achieved using hard wired I/O logic with simple electro-mechanical relays employed to provide the electrical isolation and noise immunity.

With the integration of protection, control and metering functions the number of status inputs required has dramatically increased and as a consequence modern protection relays commonly employ electronic status inputs based on an optically isolated insulation barrier.

While this approach can provide a wide operating voltage range and fast operation, a lower DC burden is required to minimize the heat dissipated within the protection relay case. Status input pick-up currents in the low mA range are common and as a consequence their stability and immunity to noise transients may be compromised.

Disturbance immunity difficulties become more apparent where control signal wiring extends outside into the switchyard or when interfacing modern equipment with traditional electro-mechanical I/O.

## Operation

### OPERATING VOLTAGE

Nominal operate voltage: Order code C: 48 / 54 V DC  
Order code D: 110 / 125 V DC  
Order code F: 220 / 250 V DC

Operating range (ABM): 50-125% of nominal operate voltage

### BURDEN

The ABM module presents a dynamic load, or burden, to voltage driven operate signals.

Operate burden: 100W < BURDEN < 150W

The high operate burden is maintained for ~50ms to help ensure operation of any cascade devices or relays. After the expiration of this short delay the ABM will self economize to reduce the burden and associated self heating that would otherwise occur.

### Operated burden:

The ABM element self economizes after ~50ms.

48 / 54V DC	<0.5 W
110 / 125V DC	<1.1 W
220 / 250V DC	<2.3 W

Maximum repetition rate: 0.5 Hz: High - Low - High burden

### THERMAL PROTECTION

A one-shot fuse is integrated in the ABM and will operate in the event the economizing circuit fails to deactivate.

This safety feature will only operate in abnormal circumstances to avoid overheating and possible loss of the status input function.

Once the thermal fuse has operated the ABM shunt load will remain open circuit and the relay status input will continue to operate but without the active burden function.

Operation of the one-shot fuse is determined by lack of operation of the LED flash when the status input is activated by a legitimate operate signal. Should this occur the ABM should be replaced.

### FRONT PANEL LAYOUT

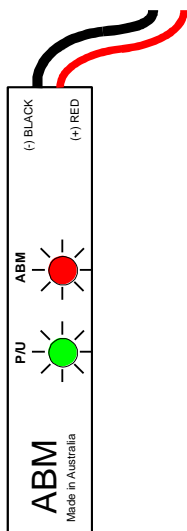

Figure 1

'Flying lead' version

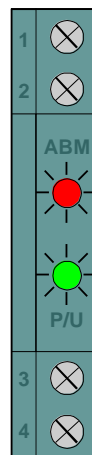

Figure 2

'Screw terminal' version

### ABM & ABMZ FUNCTIONALITY

The ABM is designed to present a shunt resistance across each status input to be protected. This ensures that a higher level of current must be delivered by the source to achieve the required pick-up voltage threshold. In order to achieve the necessary immunity from transient noise and to meet the capacitor discharge test, the operating burden of the ABM is >100W.

When the ABM detects a differential voltage, a fast-acting solid state switch is activated to shunt the input current through a wire wound power resistor.

In the event that the pick-up voltage is transient and unable to provide adequate sustained power, the energy from the transient is dissipated as heat within the ABM.

Legitimate pick-up signals that are capable of driving the high burden state are unaffected and immediately operate the digital status inputs. The ABM automatically economizes after ~50 mS to avoid thermal overload and prolonged burden on the DC supply.

A one shot thermal fuse is incorporated within the ABM as protection against possible exposure to extreme conditions that may cause it to fail to auto-economize. Even with the ABM in this 'blown' condition, the status input will continue to operate but without the high burden and noise protection functionality.

The ABM is fitted with a red LED which flashes once each time the status input is picked up to indicate correct function of the ABM.

An additional green LED is provided to indicate the presence of a continuous status input.

This is a useful feature during commissioning checks and routine maintenance inspections.

### ABMZ VERSION – MINIMUM VOLTAGE THRESHOLD

ABMZ versions provide the same Active Burden functionality as the standard ABM devices. They also incorporate circuitry to provide a minimum voltage pick-up threshold.

This feature is designed to be employed in applications where very sensitive input devices are being employed in a system susceptible to continuous background voltage coupling causing possible false activations.

The output signal of the ABMZ is not energized unless the input voltage exceeds the specified threshold voltage as nominated by the ordering code.

The ABMZ version employs a solid-state switch to connect the output terminals to the operate input voltage once the minimum voltage threshold level has been exceeded. It does not provide isolation between input and output.

Voltage threshold tolerances:  $\pm 10\%$

The ABMZ version is only available in the 'Screw terminal' housing.

Note: The ABMZ output is designed for driving status inputs of digital relays with purely resistive loads. The ABMZ output has a maximum continuous rating of 15mA and is short circuit rated for a maximum of 1 minute.

### ABMZ VERSION – TIME DELAY ON PICK-UP

ABMZ versions may be specified to provide a short pick-up time delay of 2-3ms. This delay is required to ensure compliance with capacitor discharge testing when protecting fast acting inputs such as reed repeat relays that operate in under 1ms.

This feature is also useful for application with fast acting solid-state status inputs that are do not have a programable time delay element.

## CAPACITOR DISCHARGE TEST

### ENA TS 48-4 for classes ESI 1 and ESI 2

The ABM module is specifically designed to absorb electrical energy associated with transient impulses that may be coupled onto digital input lines from electrical switching events and other such sources of disturbance.

The industry standard test for high energy, non-repetitive transients of this form is the capacitor discharge test as defined in ENA TS 48-4 for class ESI 1 and ESI 2 relays.

The standard describes the high energy impulse used for testing utilizing a 10  $\mu$ F capacitor charged to 120% of the nominal operate voltage and applied differentially directly to the input circuit of the protection or control relay.

As unprotected solid-state status inputs may typically require only a few mA to pick-up, the minimum operate voltage must be set high and the time delay  $\gg 20$ ms to pass the capacitor discharge test. Such voltage levels and time delays are usually not acceptable in the design and grading of protection and control schemes.

Figures 3 to 5 depict the time required to dissipate the capacitive discharge voltage applied during the capacitor discharge test for 5mA and 10mA status input operating currents.

The green curve represents the enhanced capacitor discharge performance provided by the ABM.

e.g. The ABM module is capable of absorbing and dissipating the total energy delivered by the capacitor discharge test for a 125V DC nominal system **in less than 5 ms.**

A minimum voltage pick up threshold and time delay should be selected to ensure that the intersection point of these parameters is above the green 'ABM' curve.

The dotted red line on figures 3 to 5 represent a 50% voltage threshold level for the status input. This level is often used as the minimum voltage pick-up to ensure the status input will not operate under a battery earth fault condition.

Where status inputs do not have a fixed or configurable minimum voltage pick-up threshold the ABMZ version may be used to provide this.

With digital input filtering typically set to 10-15ms to provide AC immunity of input signals, the ABM module is able to contain the capacitor discharge impulse within the sample filtering time thus eliminating any false or mal op readings being raised by the digital relay.

## Capacitor Discharge

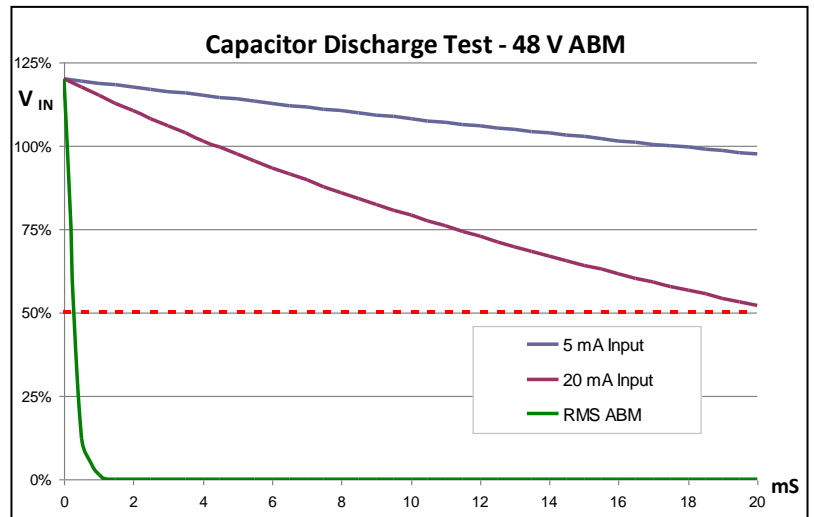

Figure 3: Voltage versus time delay curve for the 48V ABM

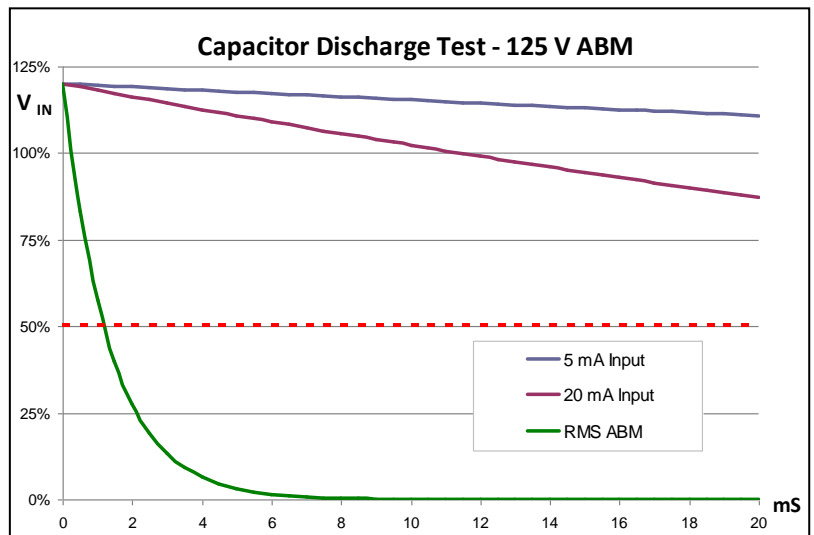

Figure 4: Voltage versus time delay curve for the 125V ABM

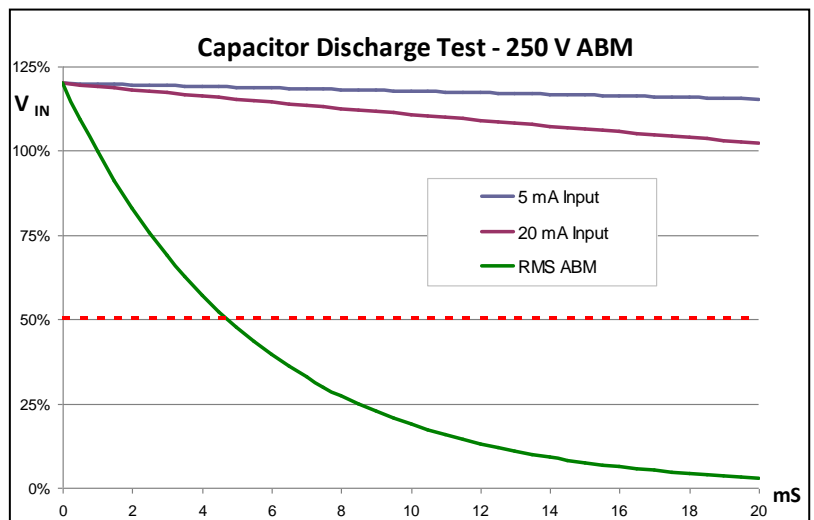

Figure 5: Voltage versus time delay curve for the 250V ABM

## Noise Immunity

### SURGE IMMUNITY

IEC 60255-22-5

Inputs to digital relays can be exposed to transients such as can be coupled into wiring systems from switching and the operation of large contactors and external environmental events such as lightning.

The standard test for immunity to such disturbances is IEC 60255-22-5 *Electrical disturbance tests – Surge immunity test*

This test consists of applying a number of **high voltage, high energy** impulses **differentially** across the relay inputs. Both Positive and Negative pulses are applied.

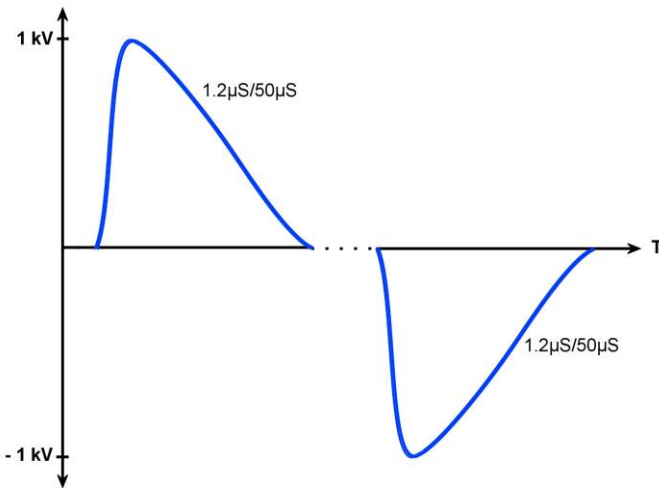

Figure 6:

IEC 60255-22-5 *Severe Environments* – 1kV differential mode

The ABM helps protect digital relay inputs from such surges by limiting the peak voltage level, clamping the major negative voltage excursions, minimizing the total transient time and by absorbing the total energy of the disturbance.

#### Peak Voltage containment

Approximately	+/- 1.5x rated voltage
Transient pulse time	Less than 25µs
Energy absorbed	100%

### HIGH FREQUENCY DISTURBANCE

IEC 60255-22-1

Digital relay inputs can be exposed to repetitive damped oscillatory waves such as those originating from closing or opening circuit breakers or disconnectors in high voltage substations or power plants.

The standard test for confirming immunity to such disturbances is IEC 60255-22-1 *Electrical disturbance tests – 1 MHz burst immunity test*

The **Differential mode** test consists of a 1 kV peak, 1MHz decaying envelope, repeated at a rate of 400 bursts per second for 2 seconds applied across the relay inputs both in the non-energized state and the operated/energized state.

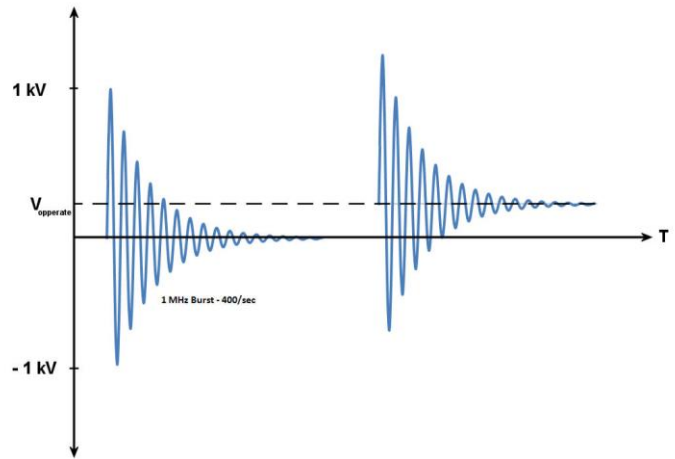

Figure 7:

IEC 60255-22-1 HFD Differential – 1kV, 1 MHz bursts

The ABM helps protect digital relay inputs from such high frequency disturbances by limiting the peak voltage level, clamping the major negative voltage excursions, and minimizing the total transient time.

#### Peak Voltage containment

Approximately	+/- 1.5x rated voltage
Burst containment time	Less than 25µs
Energy absorbed	100%

### COMMON MODE DISTURBANCES

The ABM does not require a ground connection and does not have provision for one. Common mode tests are therefore not applicable to the module and it does not compromise common mode ratings of equipment to which it is attached.

## Performance Standards

Table 1 summarizes the operating parameters and standards that the ABM complies with:

<b>Operating Voltage Range</b> The ABM is rated for continuous operation at the maximum voltages for their class as specified in ENA TS 48-4	ENA TS 48-4 Class ESI 2	Complies
<b>Operating Burden</b>	ENA TS 48-4 Class ESI 2	Complies
<b>Non Operate Energizing Current</b>	ENA TS 48-4 Class ESI 2	N/A
<b>Drop Out Voltage</b>	ENA TS 48-4 Class ESI 2	N/A
<b>Insulation Coordination – Dielectric withstand</b>	IEC 60255-5	Complies Note 2
<b>Insulation Coordination – Impulse Voltage</b>	IEC 60255-5	Complies Note 2
<b>Insulation Coordination – Insulation Resistance</b> The ABM module is potted in a specifically designed insulated housing to allow it to come into direct contact with other system wiring. Insulation: 2.5kV RMS for 1 minute	IEC 60255-5	Complies
<b>Thermal withstand</b> 1 s short term thermal withstand. The ABM module is potted in a specifically designed insulated housing to allow it to come into direct contact with other system wiring. Furthermore, in the event of exposure to sustained and excessive overvoltages, the ABM is provided with an internal, non resettable fuse to eliminate any over temperature condition that could impact other wiring.	IEC 60255-1: 2009	Complies
<b>Capacitor Discharge</b>	ENA TS 48-4 Class ESI 2	Pass
<b>High Frequency Disturbance</b>	IEC 60255-22-1 Class III	Pass
<b>Fast Transient</b>	IEC 60255-22-4 Class IV	Pass
<b>Surge Immunity</b>	IEC 60255-22-5 Class IV	Pass
<b>Vibration</b>	IEC 60255-21-1 class I	Immune No mal operation
<b>Shock</b>	IEC 60255-21-2 class I	Immune No mal operation
<b>Bump</b>	IEC 60255-21-2 class I	Immune No mal operation
<b>Seismic</b>	IEC 60255-21-3 class I	Immune No mal operation
<b>Radiated EMI</b>	IEC 60255-22-3 Class III	Immune No mal operation
<b>Conducted EMI</b>	IEC 60255-22-6	Immune No mal operation
<b>Electrostatic Discharge</b>	IEC 60255-22-2 class III	Immune No mal operation
<b>Magnetic Field</b>	IEC 61000-4-8 level 5, Class 5	Complies
<b>Temperature</b> Operation -10 C to +55 C Storage -20 C to +70 C	IEC 60068-2-1, IEC 60068-2-2	Complies
<b>Humidity</b> 40°C and 95% relative humidity	IEC 60068-2-3	Complies
<b>IP Rating</b> The RMS ABM provides a protection rating of minimum IP50	IEC 60529	Complies

Table 1

N/A: Not Applicable

Note 1: The ABM is a single circuit device with no ground connection

Note 2: Tests conducted with ABM sitting directly on copper ground plane



## ENA TS 48-4 Reference

Table 2 provides a guide for the requirements specified in the ENA TS 48-4 standard for classes ESI 1 and ESI 2 relays.

**ENA TS 48-4 standard for classes ESI 1 and ESI 2 relays**

<b>DC System Nominal Voltage</b>	48	110	220 <sup>†</sup>
<b>Relay Rated Voltage</b>	48	125	250
<b>Nominal Working Voltage</b>	54	125	250
<b>Operative Voltage range</b>	29-60	66-143	150-300
<b>Energizing Current</b> Current (mA) at or below which relay shall not operate:			
For ESI 1 Relays	10	25	25
For ESI 2 Relays	20	50	50
<b>Capacitance discharge test</b>			
For ESI 1 Relays	Not Required	Not Required	Not Required
For ESI 2 Relays	10 $\mu$ F 60 V	10 $\mu$ F 150 V	10 $\mu$ F 300 V
<b>Thermal Withstand Voltage at 40°C Ambient</b>	60	143	300
<b>Maximum Percentage AC ripple permitted on DC supply</b>	$\pm$ 12% of rated Voltage	$\pm$ 12% of rated Voltage	$\pm$ 12% of rated Voltage

Table 2

<sup>†</sup> Values for 220V Nominal System Voltages not specified in ENA TS48-4. Extrapolated values adopted by RMS for these higher voltages.

### OPERATIONAL CHECKS

Operation of the ABM and ABMZ modules can be checked while in circuit during commissioning or as part of a normal ongoing maintenance program.

To check the module:

1. From no energisation, apply an operate signal of rated voltage.
2. The RED LED will flash briefly (less than one second) showing that the active burden load is functioning correctly.
3. The GREEN LED should remain illuminated for as long as the driving voltage is present.

(And so long as it is greater than the threshold level in the case of an ABMZ)

*Note: Extreme care should be exercised if testing beyond this standard operational test for immunity to high voltage or high energy disturbances such as the Capacitor discharge test or HFD. Many of these tests impose high voltages above those of the system rating.*

*Ensure that any connected status inputs on digital relays are capable of tolerating these conditions.*

## Application

### ABM APPLICATION

#### 'Flying lead' version wiring

~250mm insulated flying leads with 1.5 sq. mm conductors are suitable for termination direct to the rear of protection and control equipment. The ABM must be wired in accordance with the polarized and color codes leads:

RED lead is positive (+)

BLACK lead is negative (-)

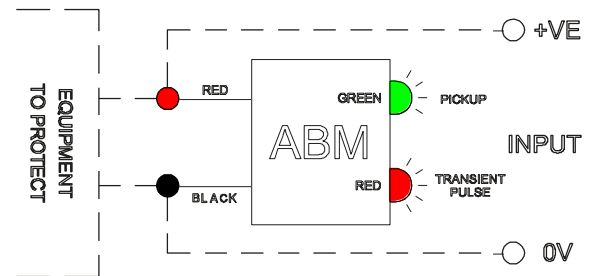

Figure 8: ABM 'Flying lead' version wiring diagram

#### 'Screw terminal' version wiring

Screw terminals are provided at the front top and bottom of the DIN rail mount housing. These are designed to accept heavy duty M4 ring lug terminals. The ABM must be wired in accordance with the following wiring diagrams:

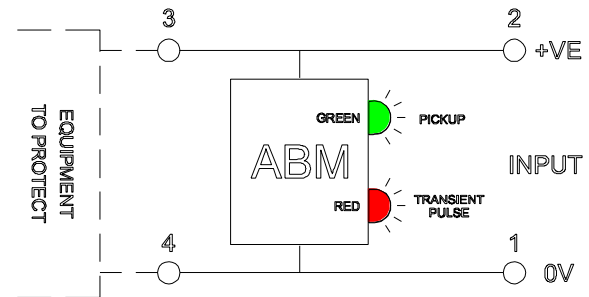

Figure 9: ABM 'Screw terminal' version wiring diagram

### ABMZ MINIMUM VOLTAGE THRESHOLD APPLICATION

#### 'Screw terminal' wiring

Screw terminals are provided at the front top and bottom of the DIN rail mount housing. These are designed to accept heavy duty M4 ring lug terminals. The ABMZ must be wired in accordance with the following wiring diagram:

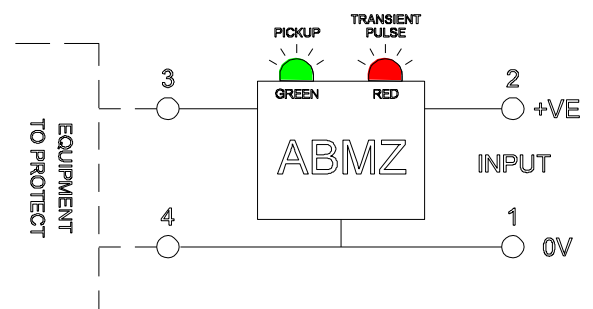

Figure 10: ABMZ - Minimum voltage pick-up option wiring

**'FLYING LEAD' VERSION**

The 'Flying lead' version is built in a compact sealed enclosure and provides two flying leads of 0.75 sq. mm multi-strand conductors for termination on site.



Figure 11: ABM 'Flying lead' version

**Mounting**

DIN rail mounting of multiple DIN rail modules allows for a compact installation close to the protection relay status inputs. The DIN rail clip may be removed if required and the module secured using a number of methods:

- ◆ self adhesive tape;
- ◆ cable ties;

**Dimensions**

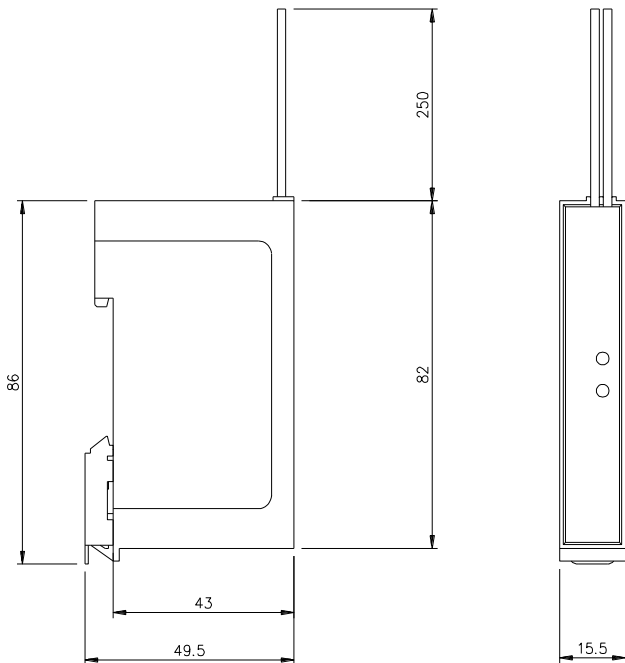

Figure 12: ABM 'Flying lead' version dimensional details

**Mounting**

**'SCREW TERMINAL' VERSION**

The 'Screw Terminal' version is built in a compact sealed enclosure and provides four M4 screw terminals for termination on site.



Figure 13: 'Screw terminal' version

**Mounting**

DIN rail mounting of multiple DIN rail modules allows for a compact installation close to the protection relay status inputs. Wiring should be kept as short as practical to minimize the circuit resistance.

**Dimensions**

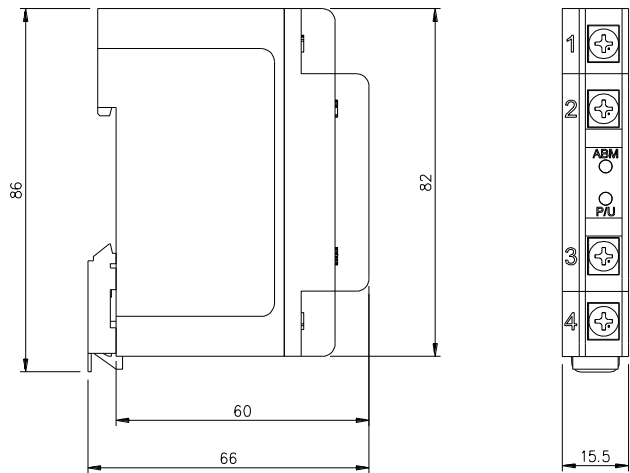

Figure 14: ABM 'Screw terminal' version dimensional details

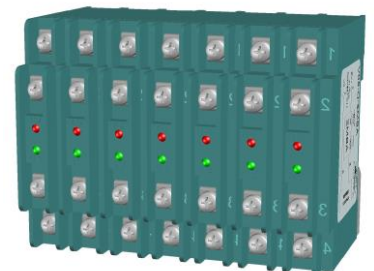

Figure 15: Array of 7x ABM 'Screw terminal' version modules



## ABM – ACTIVE BURDEN MODULE

Generate the required ordering code as follows: e.g. ABM-D-2

General Type	Order Code	
	1	2
ABM	-	-

### 1 NOMINAL AUXILIARY VOLTAGE

- C 48 / 54V DC
- D 110 / 125V DC
- F 220 / 250V DC

### 2 TERMINATION STYLE

- 1 Flying leads as per figures 11 and 12
- 2 Screw terminals as per figures 13 to 15

## ABM / ABMZ Application Warranty

The ABM is intended to be used in conjunction with digital relays specifically designed for power industry applications as an aid to improving the robustness of inputs to intermittent electrical transients and impulse noise. It is not a general panacea for making general purpose devices or inputs work in all possible power utility applications.

The ABM is a unipolar device and must be connected correctly in DC circuits only. Voltage rating selection for the ABM must be appropriate to the application.

The ABM unit will not tolerate sustained excessive, over voltage transients with high energy content. The ABM can be degraded and damaged by such conditions and is designed to ultimately fuse internally in such situations to prevent the possibility of catastrophic failure that may otherwise impact surrounding wiring.

The ABM modules are not warranted for such applications or against such failure modes.

## Ordering Information

### ABMZ – ACTIVE BURDEN MODULE & MINIMUM VOLTAGE THRESHOLD

Generate the required ordering code as follows: e.g. ABMZ-D-80V-

General Type	Order Code		
	1	2	3
ABMZ	-	-	-

### 1 NOMINAL AUXILIARY VOLTAGE

- C 48 / 54V DC
- D 110 / 125V DC
- F 220 / 250V DC

### 2 INPUT THRESHOLD VOLTAGE

- 30V 30V DC
- 60V 60V DC
- 80V 80V DC
- 150V 150V DC

### 3 INPUT TIME DELAY

- Not required
- TD Required (2-3ms)

Note: The ABMZ is only available in the 'Screw terminal' version.



**RMS Mors Smitt**  
A *Wabtec* Company

RMS Mors Smitt  
19 Southern Court  
Keysborough, VIC 3173, Australia  
Tel: +61 (0)3 8544 1200  
sales.rms@wabtec.com

Wabtec Netherlands B.V.  
Darwinstraat 10  
6718 XR Ede, Netherlands  
Tel: +31 (0)88 600 4500  
wnl\_salessupport@wabtec.com



**RMS Mors Smitt**  
A *Wabtec* Company



Visit [www.morssmitt.com/rms](http://www.morssmitt.com/rms) for the latest product information.

Due to RMS continuous product improvement policy this information is subject to change without notice

