

6RX11

Trip Relay Circuit Supervision

Features

- Low burden
- Contacts picked up for healthy trip coil condition
- Slug time delay
- Hand reset flag indicator
- 2 C/O contacts standard
- Draw out case
- Equivalent function to MVAX11
- 1TM13 specification

Application

The operating element for the 6R MATRIX supervision relay functional elements are designated 6RX & are based on our 6R Series relays.

The 6RX11 relay is designed to supervise trip relay circuits utilizing high burden trip relays such as the 6RJ & 2HSM series available from RMS.

The operating element of the 6RX11 comprises a single 6R heavy-duty attracted armature control relay with a single operating coil & delay slug. It has two dropping resistors R1 & R2 of equal ohmic value, connected in series with the coil.

If the circuit being supervised becomes open circuited or if the supply fails, the relay will become reenergized and an alarm or visual indication will be given.

Under healthy conditions the relay coil is energized via the dropping resistor R1 as shown below (Tripping relay circuit). If the circuit being supervised becomes open circuit or if the supply fails, the relay will become de-energized & an alarm is given (2 C/O contacts & flag indication).

To prevent the alarm being given when the circuit being supervised is operated the relay coil is maintained via the dropping resistor R2. For this purpose, an additional normally open contact is required from the latching tripping relay as depicted at right. A short time delay (>100ms), is incorporated to hold up the alarm relay during a normal trip relay operation.

Contacts are constructed from silver, shaped & positioned to ensure reliable, low resistance operation. Over travel of the contacts during each operation causes a wiping action ensuring a clean "make".

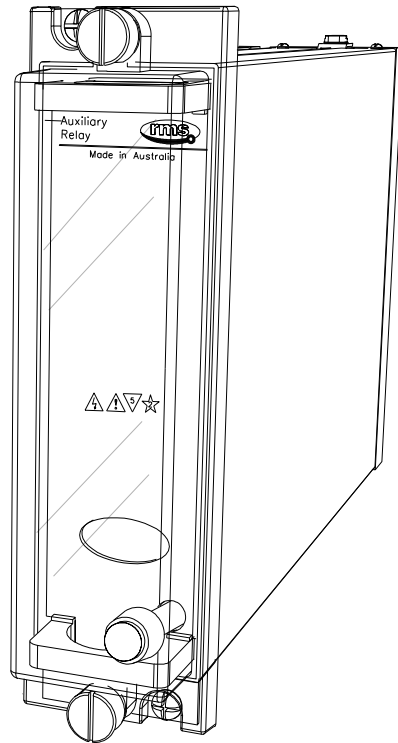

2M28 draw out case

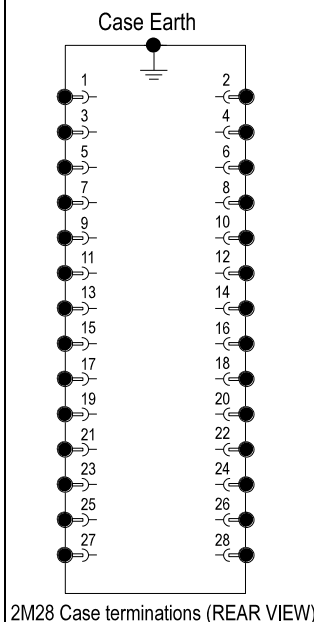

2M28 Case terminations (REAR VIEW)

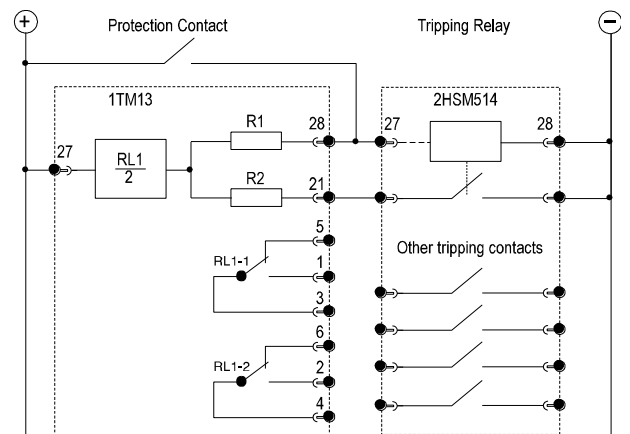

CIRCUIT RESISTANCE & BURDEN

The 6RX11 circuit design is optimized to minimize the supervision current in the tripping relay circuit to avoid the possibility of nuisance tripping. The total series resistance provided by the combination of RL1/R1 & RL1/R2 is tabulated below. Resistance of the CB coil must be much less than this figure to ensure adequate supervision current flows through the 6RX11 element under normal conditions.

Nominal supply	~Resistance (ohms)	Burden * (Watts)
32V DC	2,200	<0.6
48V DC	3,100	<0.9
110V DC	8,000	<1.7
125V DC	8,000	<2.2

TRIP SUPPLY BURDEN

* Actual operating burden is dependent on the tripping relay resistance

THERMAL RATING

All operate & reset circuits are designed to withstand continuous application of 120% of nominal voltage

FLAG OPERATION

Each relay element is supplied with a flag (target) indicator. The indicator consists of a high visibility solid dayglow orange mechanical flag.

Operation: Drops on coil de-energisation.
 Reset: Hand reset.

OPERATING VOLTAGE RANGE

Guaranteed operation between 70% & 120% of nominal rated operating voltage.

NOMINAL OPERATING VOLTAGES

24, 32, 48, 110, 125, 220, 240 & 250V DC available.

DROP OUT VOLTAGE

Drop out voltage: >10% of nominal rated operate voltage.

CONTACTS

2 C/O standard
 Up to 4 M or B contacts - user to specify combination of make & break contacts

INSULATION WITHSTAND

in accordance with IEC 255-5:

- 2KV RMS & 1.2/50 5KV impulse between:
- ◆ all terminals & frame
- ◆ each contact group
- ◆ all contacts & coil

CASE SIZE

2M28-S draw out case

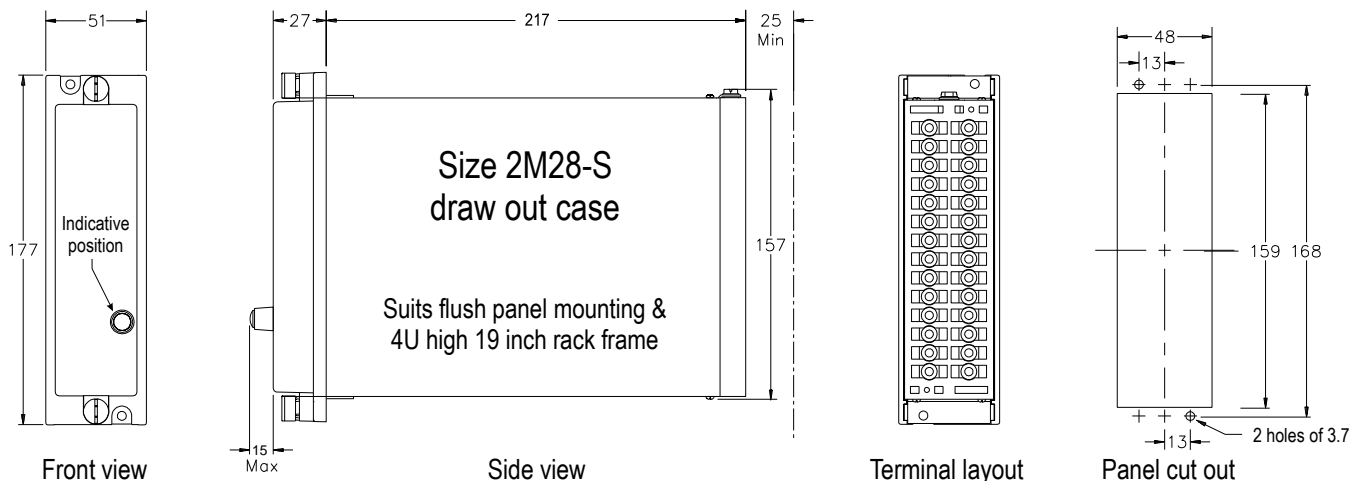

Ordering Codes

Generate the required ordering code as follows:
 e.g. 6RX11-D-2C

6RX11 1

1 NOMINAL OPERATE VOLTAGE

- | | |
|-----------|-----------|
| A 24V DC | E 125V D |
| B 32V DC | G 220V DC |
| C 48V DC | H 240V DC |
| D 110V DC | F 250V DC |

5 CONTACT ARRANGEMENT – 2 C/O standard

6R RELAY CONTACT RATINGS

Make & Carry Continuously

3,000 VA AC resistive with maximums of 660V & 12A
 3,000 W DC resistive with maximums of 660V & 12A

Make & Carry for 3 Seconds

7,500 VA AC resistive with maximums of 660V & 30A
 7,500 W DC resistive with maximums of 660V & 30A

AC Break Capacity

3,000 VA AC resistive with maximums of 660V & 12A

DC Break Capacity (Amps)

Voltage		24V	48V	125V	250V
Resistive rating		12	2	0.5	0.25
L/R=40ms	Maximum break	12	1	0.25	0.15



RMS Mors Smitt
A *Wabtec* Company

RMS Mors Smitt
19 Southern Court
Keysborough, VIC 3173, Australia
Tel: +61 (0)3 8544 1200
sales.rms@wabtec.com

Wabtec Netherlands B.V.
Darwinstraat 10
6718 XR Ede, Netherlands
Tel: +31 (0)88 600 4500
wnl_salessupport@wabtec.com



RMS Mors Smitt
A *Wabtec* Company



Visit www.morssmitt.com/rms for the latest product information.

Due to RMS continuous product improvement policy this information is subject to change without notice