



## Features

- Meets NGTS 2.19.1999
- Electrical set and reset contacts and flag
- 10 contact version
- Electrical reset inhibit function
- Alternative to MVAJ34 and TR431 relays

Technical Bulletin

**6RJ34-10**

**Bistable Control Relay**

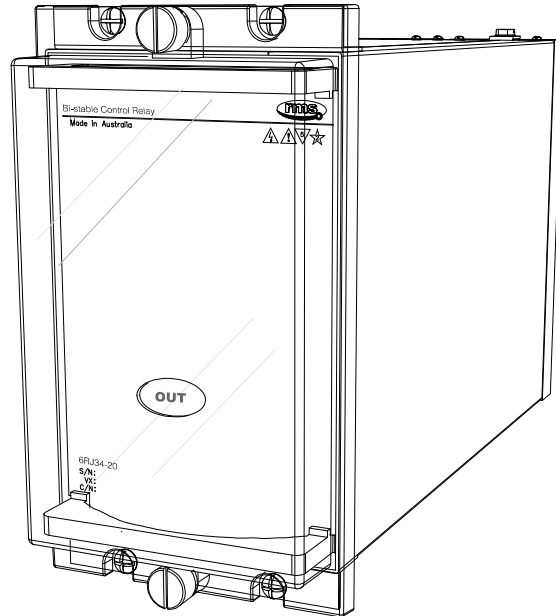

4M56 draw out case

## Application

Made in Australia

The 6RJ34 is a bi-stable control relay designed to switch protection and auto reclosing IN and OUT of service from a remote point via pilot wires.

Application of a control signal to the operate coil inputs will cause the relay to pick up changing the state of the contacts and flag to the OUT condition.

Application of a control signal to the reset coil inputs will cause the relay to drop out reverting the contacts and flag to the IN condition.

The operate and reset coils are automatically protected from thermal damage by a series cut throat contacts once the relay contacts have changed state.

An electrical reset inhibit function is provided to isolate the reset circuit when a voltage is applied to the operate coil. This avoids the possibility of the relay cycling between the IN and OUT state if the operate and reset coils are energized at the same time.

A feature of the design is that the 6RJ34 will neither operate nor reset if 110V AC 50Hz rms is applied across either the operate or reset circuits in accordance with National Grid Company SPEC.NGTS 2.19.1999.

Up to 10 contacts may be specified in any combination with a maximum of 5 break.

Where 20 contacts are required refer to the 6RJ34-20 Technical Bulletin.



## Terminal Wiring

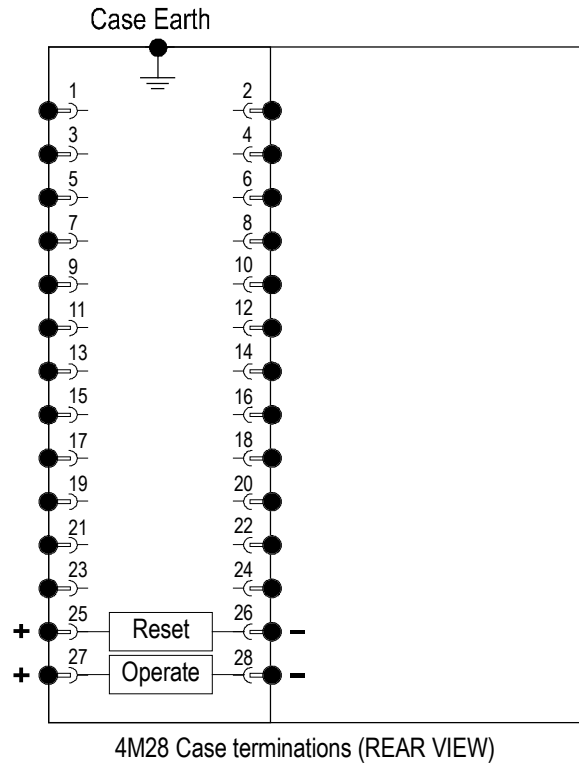

6RJ34-10 Terminal Numbers										
Contacts	1-3	2-4	5-7	6-8	9-11	10-12	13-15	14-16	17-19	18-20
10M	M	M	M	M	M	M	M	M	M	M
9M+1B	M	M	M	M	M	M	M	M	M	B
8M+2B	M	M	M	M	M	M	M	M	B	B
7M+3B	M	M	M	M	M	M	M	B	B	B
6M+4B	M	M	M	M	M	M	B	B	B	B
5M+5B	M	M	M	M	M	B	B	B	B	B

Table 1

### OPERATING & RESET BURDENS

Burdens during pick up and reset at nominal.  
 48/54V DC: <15W  
 110/125V DC: <25W  
 220/250V DC: <50W

### OPERATED BURDEN

Burden after operation  
 Operate coil: Zero  
 Reset coil: Zero  
 Reset interlock: <1W

### COIL THERMAL RATING

The operate and reset circuits are designed to withstand continuous application of 120% of nominal voltage. Both the operate and reset coils are protected by use of instantaneous series cut-off contact arrangements in both coils.

Continuous application of both the pick up coil and the reset coil will defeat the cut throat contacts and result in overheating and thermal damage to both coils and associated circuits.

### OPERATING TIME (Measured to first touch)

0 Ohm pilot: <50ms at nominal rated operating voltage  
 200 Ohm pilot: <75ms at nominal rated operating voltage

### CONTACT OPERATION

Latching contacts with electrical reset.

### FLAG OPERATION

Latching flag with electrical reset.  
 Flag indicates **OUT** when operated  
 Flag indicates **IN** when reset  
 Flag must be in the operate position before the flag can be reset.  
 Flag must be in reset position before the flag can be operated.

### OPERATING VOLTAGE RANGE

With pilot wire resistance in series with operate and reset coils:

Dual Rated Voltage	0 Ohm pilot	200 Ohm pilot
48/54V DC	37.5 - 60V DC	46 - 56V DC
110/125V DC	87.5 - 137.5V DC	87.5-137.5V DC
220/250V DC	122 - 286V DC	175-275V DC

Note: The above voltage range allows for correct operation of the relay tripping systems even when there is a loss of battery charger supply for considerable periods.

To ensure guaranteed operation at the above DC supply conditions the relay is manufactured to operate at a lower level to guarantee operation if the voltage falls to the lower voltage in the operating range. Consequently, it will be found that these relays will operate below the state operating range, this is normal and correct.

The lower voltage figure in the range does not indicate the relay pickup voltage.

### MINIMUM OPERATING CURRENT

Operate and reset: >25mA

### AC VOLTAGES

The 6RJ34 will neither operate nor reset if 110V AC 50Hz rms is applied across either coil circuit for 5s.

## Technical Data

### ELECTRICAL RESET INTERLOCK

Standard bistable control relays can be wired into a configuration where a 'race' condition is possible. If the reset circuit is held energized while the relay operate input also remains energized, the relay will oscillate between the operated and reset states. The 6RJ34 relay is fitted with a reset interlock feature to eliminate this condition.

This protection function is achieved using an internal relay that picks up when a signal is applied to the operate coil. When picked up a contact isolates the reset circuit.

The relay can only be reset to the IN state provided an operate signal is not present.

### CONTACTS

10 contacts standard  
 User to specify combination of make & break contacts

Refer to the 6RJ34-20 Technical Bulletin for details on the 20 contact version.

### 6R RELAY CONTACT RATINGS

#### Make and Carry Continuously

3,000 VA AC resistive with maximums of 660V and 12A  
 3,000 W DC resistive with maximums of 660V and 12A

#### Make and Carry for 3 Seconds

7,500 VA AC resistive with maximums of 660V and 30A  
 7,500 W DC resistive with maximums of 660V and 30A

#### AC Break Capacity

3,000 VA AC resistive with maximums of 660V and 12A

#### DC Break Capacity (Amps)

Voltage		24V	48V	125V	250V
Resistive rating		12	2	0.5	0.25
L/R=40ms	Maximum break	12	1	0.25	0.15

### INSULATION WITHSTAND in accordance with IEC 60255-5:

2KV RMS and 1.2/50 5KV impulse between:

- ◆ all terminals and frame
- ◆ each contact group
- ◆ all contacts and coil

### CASE SIZE

4M28-S draw out case

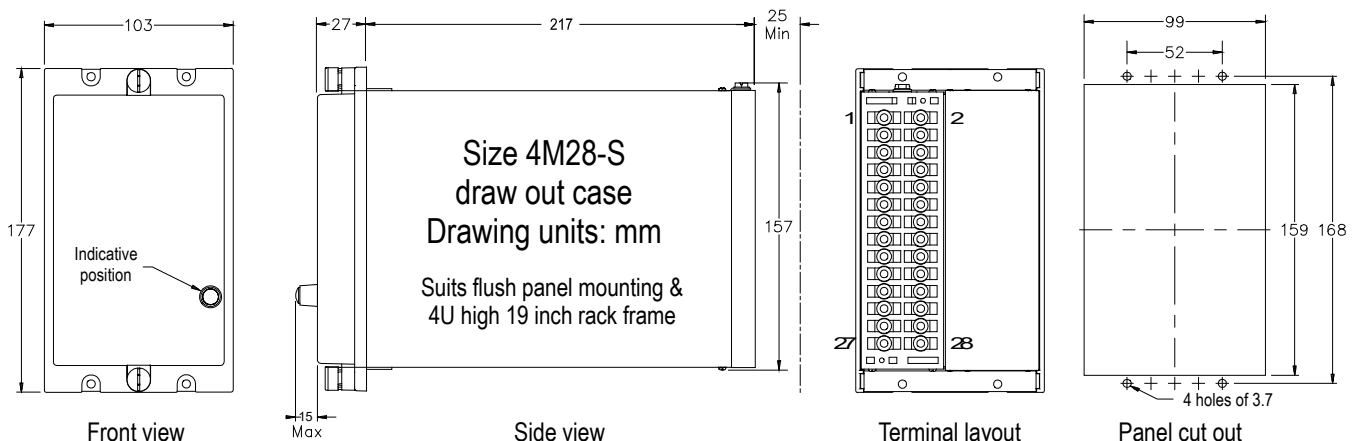



## Ordering Codes

Generate the required ordering code as follows:

e.g. 6R34-10-D-5M5B

6RJ34-10 

1

2

**1** NOMINAL OPERATE VOLTAGE

C 48/54V DC  
D 110/125V DC  
F 220/250V DC

**3** CONTACT ARRANGEMENT (As per table 1)

Specify the number of "MAKES" followed by M; i.e. 5M

Specify the number of "BREAKS" followed by B; i.e. 5B



**RMS Mors Smitt**  
A *Wabtec* Company

---

**RMS Mors Smitt**  
19 Southern Court  
Keysborough, VIC 3173, Australia  
Tel: +61 (0)3 8544 1200  
sales.rms@wabtec.com



**RMS Mors Smitt**  
A *Wabtec* Company

**Wabtec Netherlands B.V.**  
Darwinstraat 10  
6718 XR Ede, Netherlands  
Tel: +31 (0)88 600 4500  
wnl\_salessupport@wabtec.com



Visit [www.morssmitt.com/rms](http://www.morssmitt.com/rms) for the latest product information.

Due to RMS continuous product improvement policy this information is subject to change without notice