

High Speed Tripping Relay 6RJ25

For fast and secure multi-trip protection applications.

- > High speed operation
- > High burden
- > Hand & electrical reset contacts
- > Independent hand reset flag
- > 5 or 10 contacts
- > Equivalent function to MVAJ25
- > 2HSM519 specification



Description

The 6RJ25 is a high burden relay suitable for application in high security circuit breaker tripping circuits & in particular where the initiating contact may be remote from the relay. The high burden may also allow the satisfactory operation of external series elements.

The 6RJ25 has a high burden to provide immunity to capacitance discharge currents & power to the coil is cut off at operation or is economized to a low figure to provide thermal protection.

High burden tripping relays are designed to withstand the 10uF capacitor discharge test such that the relay will not operate when a 10uF capacitor charged to 120% of nominal operating voltage is applied across the coil of the relay.

The high speed relay coil is automatically protected from thermal damage by a series cut throat contact once the relay contacts have picked up & latched.

The contacts can be reset using the front panel reset push button or via the electrical reset input. The electrical reset coil is automatically protected from thermal damage by a series cut throat contact once the relay contacts have been reset. The trip flag can only be reset via the independent front panel reset push button after the contacts have been reset.

This feature allows the flag indication to be maintained as a record of trip operation even if the contacts have been electrically reset by remote control or by an auto reclose scheme.

The 6RJ23 version may be specified where the contacts & flag are reset simultaneously.



RMS	Alstom	Reyrolle	Contacts	Functional Description
6RJ25-5	MVAJ25, MVAJ055	TR241	5	High burden high speed trip relay Hand & electrical reset contacts Independent hand reset flag
6RJ25-10	MVAJ25, MVAJ105	TR241	10	
6RJ25-20	MVAJ205	TRA241	20	

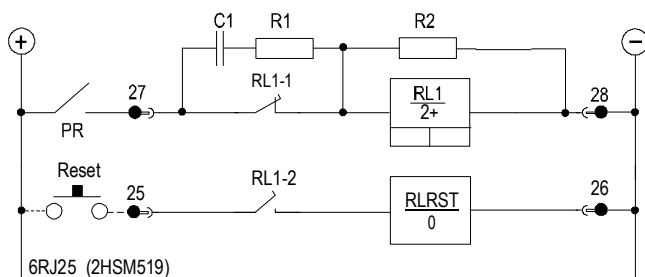

Contact Operation

Latching contacts with front panel hand reset button & reset coil for remote electrical reset. Continuous application of a control voltage to both the trip & reset inputs must be avoided otherwise thermal damage to both coils may occur. Likewise holding the reset button in the depressed position with a trip signal is applied may result in thermal damage to the high speed operate coil.

Flag Operation

Drops on coil energisation.
 Independent hand reset button.
 Contacts must be in the reset position before the flag can be reset.

AC Voltages

Standard 6RJ relays are not intended for operation with AC voltages. Application of continuous AC voltage below the pick up level will cause excessive power dissipation in the capacitor discharge resistor & likely result in thermal damage to the device.

Contacts

5 or 10 contacts
 User to specify combination of make & break contacts

Electrical Reset Mechanism

Operate voltage: As per specified operate voltage.
 Reset cut off: Instantaneous with main relay reset.

Continuous application of both the high speed pick up coil & the reset coil (or contact reset button), will defeat the cut throat contact & result in overheating & thermal damage to both coils & associated circuit.

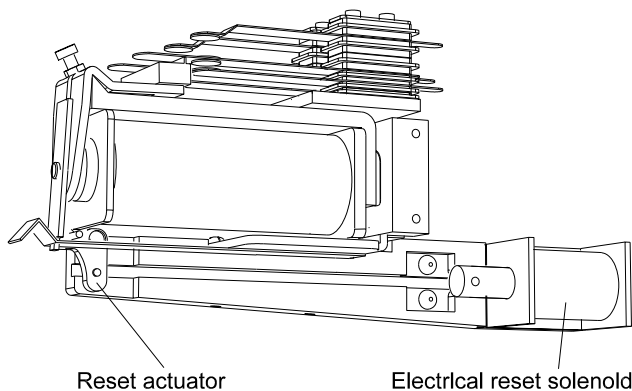

Operating Burden

High burden relays	150W Maximum
Reset Coils	40W Maximum

Operated Burden

Hand reset contacts	Zero
Rest Coils	Zero

Coil Thermal Rating

Operating Circuit	Withstand 120% of Nominal voltage.
Coil Element (150 watt Max)	30 Secs

Operating Time

<10ms at nominal operating voltage

Operating Voltage Range

Between 65% and 120% of nominal rated operating voltage

Note: The 65% of nominal value allows for correct operation of the tripping systems even when there is a loss of battery charger supply for considerable periods.

To ensure guaranteed operation at 65% of nominal voltage the relay is manufactured to operate at a lower level to guarantee operation if the voltage falls to 65% of nominal voltage. Consequently, it will be found that these relays will operate below 65% of nominal voltage, this is normal and correct and does not affect relay stability due to the high burden characteristics of the relay.

The 65% of nominal voltage figure does not indicate the relay pickup voltage.

Nominal Operating Voltages

24, 32, 48, 110, 125, 220, 240 & 250V DC available

Minimum Operating Current

High Burden Relays	100mA
--------------------	-------

Contact Ratings

Make and carry Continuous	3,000 VA AC resistive 3,000 W DC resistive Limited at both 660 V and 12 A			
	7,500 VA AC resistive 7,500 W DC resistive Limited at both 660 V and 30 A			
Make and carry for 3s	3,000 VA AC resistive Limited at both 660 V and 12 A			
AC break capacity	3,000 VA AC resistive Limited at both 660 V and 12 A			
DC break capacity (Amps)				
Voltage	24V	48V	125V	250V
Resistive Rating	12	2	0.5	0.3
Inductive Rating L/R=40ms	12	1	0.25	0.15

Insulation

Standard	IEC 60255-5
Category	3
Between all terminals and earth	2.0 kV rms for 60 s
Between Independent Circuits	2.0 kV rms for 60 s
Across Normally Open Contacts	1.0 kV rms for 60 s
3 Positive and 3 negative Impluses:	
Between all terminals and earth	5.0 kV 1.2/50 μ s 0.5 J
Between Independent circuits	5.0 kV 1.2/50 μ s 0.5 J

Capacitor Discharge

Standard	ENA TS 48-4 2010 ISSUE 4
Nominal voltage	Capacitor discharge test
32 V dc	Not applicable
48 V dc	
110 V dc	No mal op. for
125 V dc	Capacitor discharge:
230 V dc *	C = 10 μ F
240 V dc *	V = 120% of Vnominal
250 V dc *	(* 275V Maximum)

Temperature

Standard	IEC 60068-2-1/2
Operating Range	-10 to +55 degrees Celsius
Storage Range	-25 to +70 degrees Celsius

Humidity

Standard	IEC 60068-2-78
Operating Range	40 degrees Celsius and 93% RH non condensing

Enclosure protection

Standard	IEC 60529
Installed	IP5x

Vibration - Sinusoidal

Standard	IEC 60255-21-1 Class I	
Vibration Response	0.5gn	\leq 5%
Vibration Endurance	1.0gn	\leq 5%

Shock and Bump

Standard	IEC 60255-21-2 Class I	
Shock Response	5gn, 11ms	\leq 5%
Shock Withstand	15gn, 11ms	\leq 5%
Bump Test	10gn, 16ms	\leq 5%

Seismic

Standard	IEC 60255-21-3 Class 2	
Seismic Response Type	Level	Variation
Horizontal	2.0 gn	\leq 5%
Vertical	1.0 gn	\leq 5%

Mechanical Classification

Durability - 0.1 Hz maximum repetition rate	$>10^5$ operations at no load
	$>10^4$ operations at full load

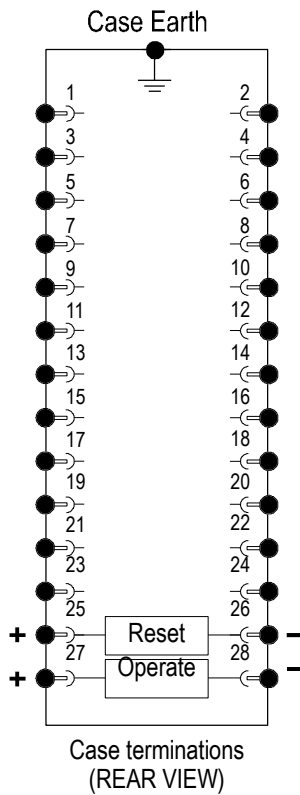

6RJ25-5 Terminal Numbers					
Contacts	1-3	2-4	5-7	6-8	9-11
5M	M	M	M	M	M
4M+1B	M	M	M	M	B
3M+2B	M	M	M	B	B
2M+3B	M	M	B	B	B
1M+4B	M	B	B	B	B
5B	B	B	B	B	B

6RJ25-10 Terminal Numbers										
Contacts	1-3	2-4	5-7	6-8	9-11	10-12	13-15	14-16	17-19	18-20
10M	M	M	M	M	M	M	M	M	M	M
9M+1B	M	M	M	M	M	M	M	M	M	B
8M+2B	M	M	M	M	M	M	M	M	B	B
7M+3B	M	M	M	M	M	M	M	B	B	B
6M+4B	M	M	M	M	M	M	B	B	B	B
5M+5B	M	M	M	M	M	B	B	B	B	B
4M+6B	M	M	M	M	B	B	B	B	B	B
3M+7B	M	M	M	B	B	B	B	B	B	B
2M+8B	M	M	B	B	B	B	B	B	B	B
1M+9B	M	B	B	B	B	B	B	B	B	B
10B	B	B	B	B	B	B	B	B	B	B

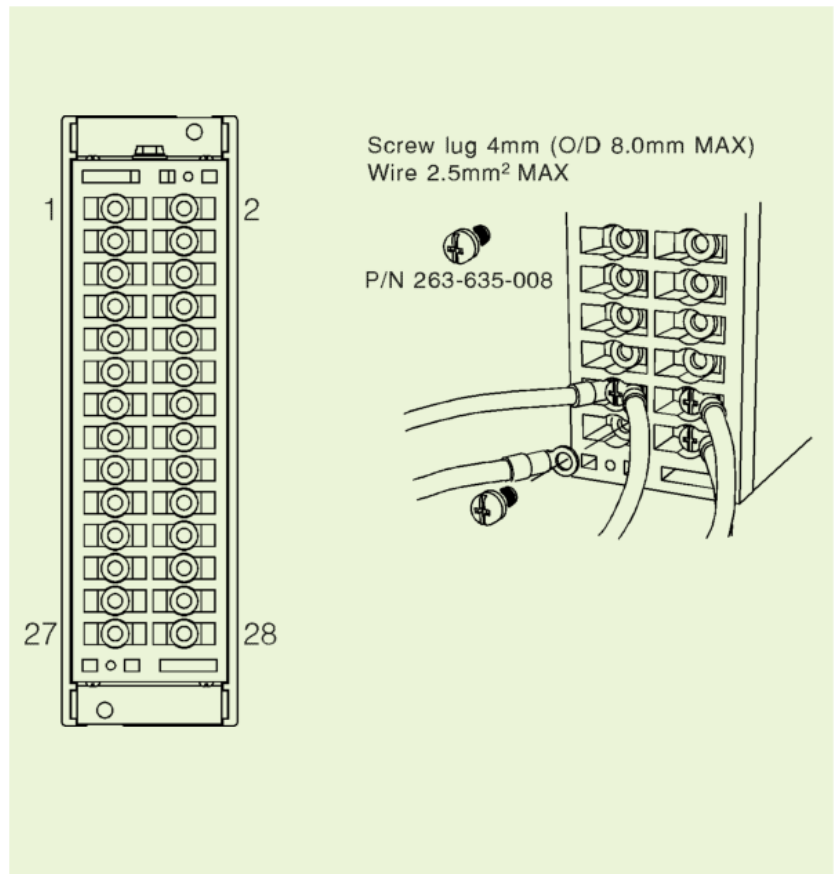
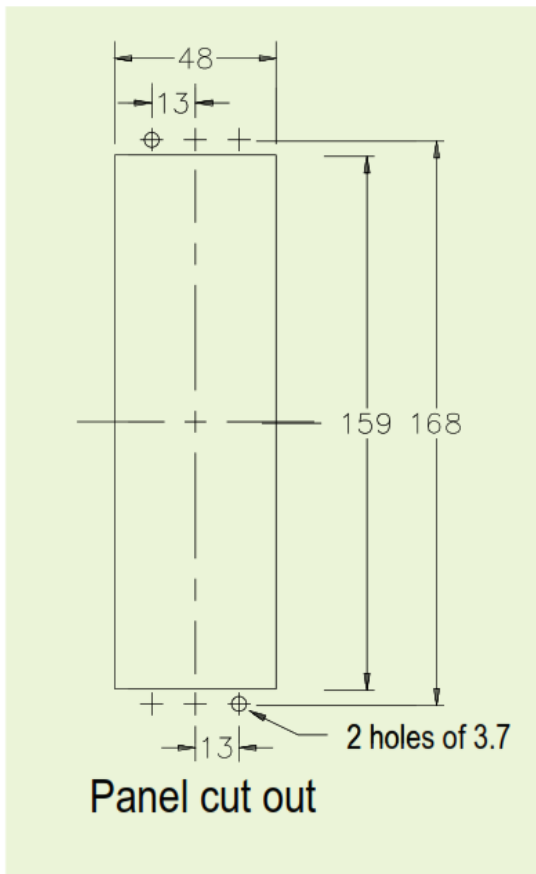
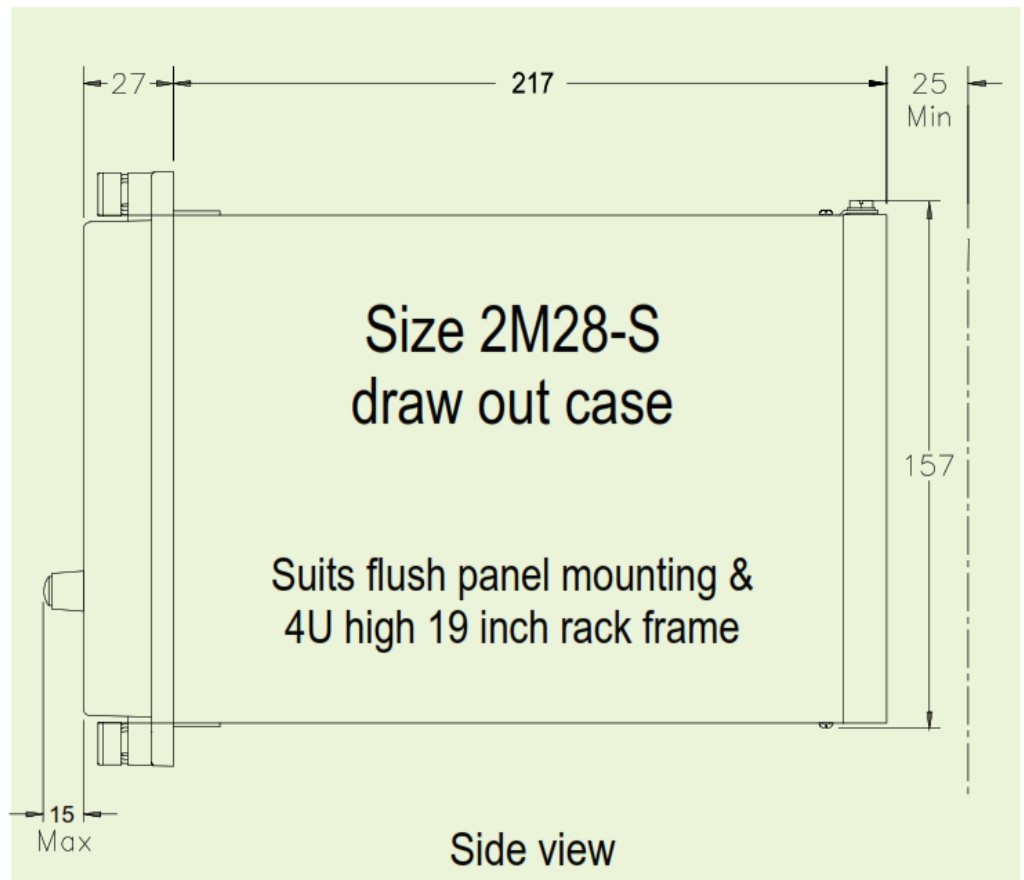
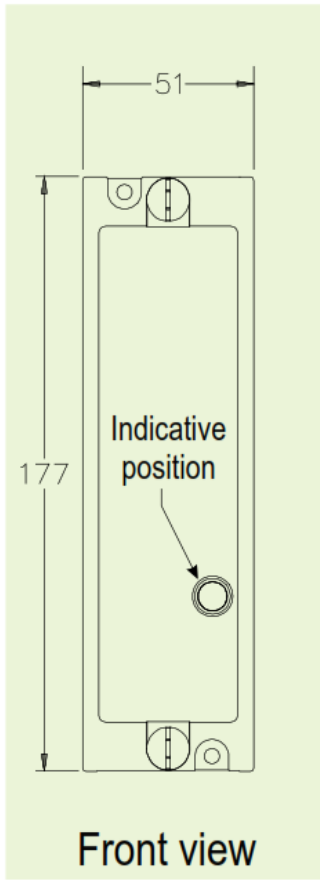

Relay Order Code

6RJ25 -		<input type="text"/>	<input type="text"/>	<input type="text"/>
Number of Contacts	5	5 Contacts		
	10	10 Contacts		
Nominal Operate Voltage	A	24V DC		
	B	32V DC		
	C	48V DC		
	D	110V DC		
	E	125V DC		
	F	250V DC		
	G	220V DC		
	H	240V DC		
Contact Arrangement	0 M	Specify the number of "MAKES" followed by M		
	0 B	Specify the number of "BREAKS" followed by B		

Example Ordering Code: **6RJ25-10-D-8M 2B**

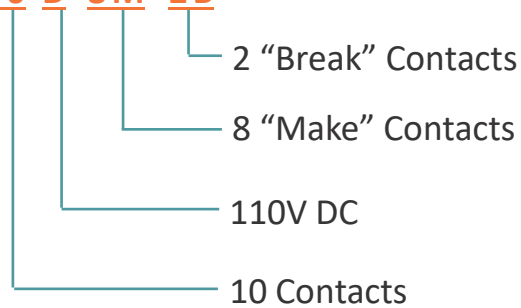

RMS Mors Smitt
19 Southern Court
Keysborough, VIC 3173, Australia
Tel: +61 (0)3 8544 1200
sales.rms@wabtec.com

Wabtec Netherlands B.V.
Darwinstraat 10
6718 XR Ede, Netherlands
Tel: +31 (0)88 600 4500
wnl_salessupport@wabtec.com



Visit www.morssmitt.com/rms for the latest product information.
Due to RMS continuous product improvement policy this information is subject to change without notice.