

## Features

- High speed operation
- High burden
- Electrical reset contacts
- Independent hand reset flag
- 20 contacts
- Equivalent function to MVAJ24
- 2HSM516 specification

## Application

The effect of a fault on a power system is dependent on the speed with which the fault can be detected & isolated. The 6RJ Series multi-contact high-speed trip relays are used for this isolating function providing simultaneous tripping outputs.

A high speed coil provides fast operation (<12ms at nominal voltage), with specially constructed anti bounce buffers ensuring effective damping of the contacts to avoid excessive bounce.

## 6RJ24-20

### High Burden Electrical Reset Trip & Lockout Relay

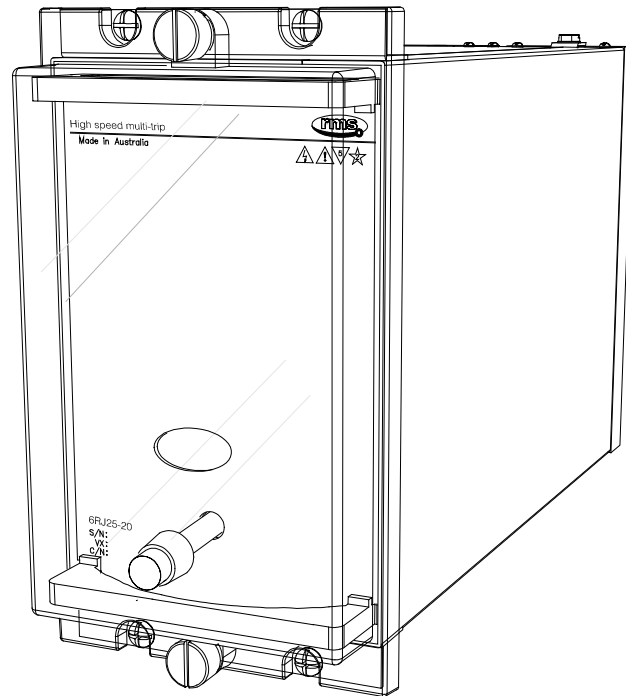

4M56 draw out case

### High Burden 20 Contact Tripping Relay

The 6RJ24 is a high burden relay suitable for application in high security circuit breaker tripping circuits & in particular where the initiating contact may be remote from the relay. The high burden may also allow the satisfactory operation of external series elements.

The 6RJ24 has a high burden to provide immunity to capacitance discharge currents & power to the coil is cut off at operation or is economized to a low figure to provide thermal protection.

High burden tripping relays are designed to withstand the 10uF capacitor discharge test such that the relay will not operate when a 10uF capacitor charged to 120% of nominal operating voltage is applied across the coil of the relay.

The high speed relay coil is automatically protected from thermal damage by a series cut throat contact once the relay contacts have picked up & latched.

The contacts can only be reset via the electrical reset input. The electrical reset coil is automatically protected from thermal damage by a series cut throat contact once the relay contacts have been reset.

The trip flag may only be reset via the independent front panel reset push button after the contacts have been reset. This feature allows the flag indication to be maintained as a record of trip operation even if contacts are electrically reset by remote control or by an auto reclose scheme.

The 6RJ23 version may be specified where the contacts & flag are reset simultaneously.

### Series Elements

External relay elements are often employed for additional flagging & alarm functions. These elements are typically much slower than the primary high speed tripping relay so care must be taken to ensure reliable operation of the series element before the series trip signal is cut off or economized. In these circumstances a 6RJ relay with a time delayed (TD) cut off should be employed.

## Terminal Wiring

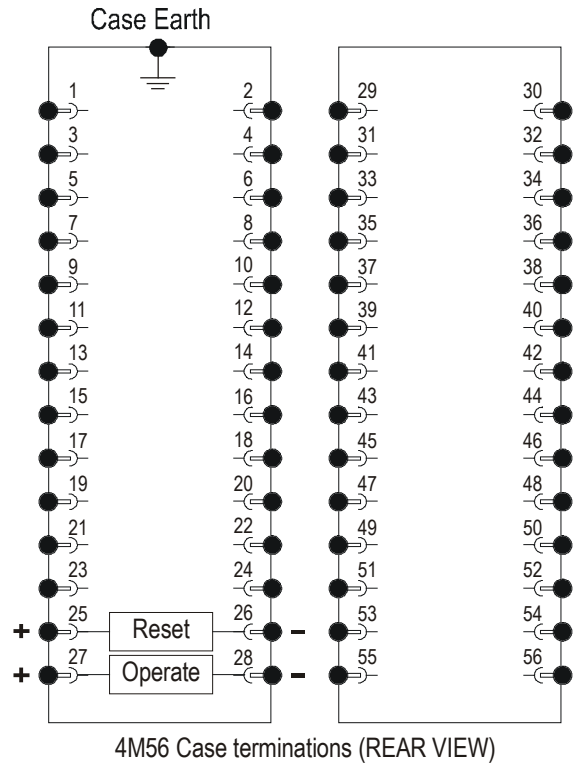
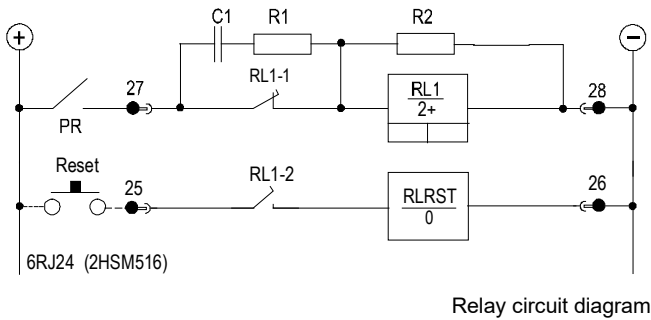

6RJ24-20 Terminal Numbers																				
	1	2	5	6	9	10	13	14	17	18	21	22	29	30	33	34	37	38	41	42
	&	&	&	&	&	&	&	&	&	&	&	&	&	&	&	&	&	&	&	&
	3	4	7	8	11	12	15	16	19	20	23	24	31	32	35	36	39	40	43	44
Contacts	1	2	3	4	5	6	7	8	9	10	11	12	13	14	15	16	17	18	19	20
20M	M	M	M	M	M	M	M	M	M	M	M	M	M	M	M	M	M	M	M	M
19M+1B	M	M	M	M	M	M	M	M	M	M	M	M	M	M	M	M	M	M	M	B
18M+2B	M	M	M	M	M	M	M	M	M	M	M	M	M	M	M	M	M	M	B	B
17M+3B	M	M	M	M	M	M	M	M	M	M	M	M	M	M	M	M	M	B	B	B
16M+4B	M	M	M	M	M	M	M	M	M	M	M	M	M	M	M	M	B	B	B	B
15M+5B	M	M	M	M	M	M	M	M	M	M	M	M	M	M	M	B	B	B	B	B
14M+6B	M	M	M	M	M	M	M	M	M	M	M	M	M	M	B	B	B	B	B	B
13M+7B	M	M	M	M	M	M	M	M	M	M	M	M	M	B	B	B	B	B	B	B
12M+8B	M	M	M	M	M	M	M	M	M	M	M	M	B	B	B	B	B	B	B	B
11M+9B	M	M	M	M	M	M	M	M	M	M	M	B	B	B	B	B	B	B	B	B
10M+10B	M	M	M	M	M	M	M	M	M	M	B	B	B	B	B	B	B	B	B	B
9M+11B	M	M	M	M	M	M	M	M	M	B	B	B	B	B	B	B	B	B	B	B
8M+12B	M	M	M	M	M	M	M	M	B	B	B	B	B	B	B	B	B	B	B	B
7M+13B	M	M	M	M	M	M	M	B	B	B	B	B	B	B	B	B	B	B	B	B
6M+14B	M	M	M	M	M	M	B	B	B	B	B	B	B	B	B	B	B	B	B	B
5M+15B	M	M	M	M	M	B	B	B	B	B	B	B	B	B	B	B	B	B	B	B
4M+16B	M	M	M	M	B	B	B	B	B	B	B	B	B	B	B	B	B	B	B	B
3M+17B	M	M	M	B	B	B	B	B	B	B	B	B	B	B	B	B	B	B	B	B
2M+18B	M	M	B	B	B	B	B	B	B	B	B	B	B	B	B	B	B	B	B	B
1M+19B	M	B	B	B	B	B	B	B	B	B	B	B	B	B	B	B	B	B	B	B
20B	B	B	B	B	B	B	B	B	B	B	B	B	B	B	B	B	B	B	B	B

**OPERATING BURDEN** (Burden during pick up at nominal)

High burden relays: 150W Maximum  
Reset coils: 40W Maximum

**OPERATED BURDEN** (Burden after pick up at nominal)

Hand reset contacts: Zero  
Reset coils: Zero

**COIL THERMAL RATING**

The operate circuit is designed to withstand continuous application of 120% of nominal voltage. The high speed operate coil element (150 watt max.) has a thermal rating of 30 seconds, however this is protected by use of the instantaneous series cut-off contact arrangement.

**OPERATING TIME**

Less than 12ms at nominal rated operating voltage.

**CONTACT OPERATION**

Latching contacts with front panel hand reset button & reset coil for remote electrical reset.

**FLAG OPERATION**

Drops on coil energisation.  
Independent hand reset button.  
Contacts must be reset position before the flag can be reset.

**OPERATING VOLTAGE RANGE**

Guaranteed operation between 65% & 120% of nominal rated operating voltage.

Note: The 65% of nominal value allows for correct operation of the tripping systems even when there is a loss of battery charger supply for considerable periods.

To ensure guaranteed operation at 65% of nominal voltage the relay is manufactured to operate at a lower level to guarantee operation if the voltage falls to 65% of nominal voltage. Consequently, it will be found that these relays will operate below 65% of nominal voltage, this is normal and correct and does not affect relay stability due to the high burden characteristics of the relay.

The 65% of nominal voltage figure does not indicate the relay pickup voltage.

**NOMINAL OPERATING VOLTAGES**

24, 32, 48, 110, 125, 220, 240 & 250V DC available.

**AC VOLTAGES**

Standard 6RJ relays are not intended for operation with AC voltages. Application of continuous AC voltage below the pick up level will cause excessive power dissipation in the capacitor discharge resistor & likely result in thermal damage to the device.

**MINIMUM OPERATING CURRENT**

High burden relays: 100mA

**ELECTRICAL RESET**

Operate voltage: As per specified operate voltage.  
Reset cut off: Instantaneous with main relay reset.

Continuous application of both the high speed pick up coil & the reset coil will defeat the cut throat contact & result in overheating & thermal damage to both coils & associated circuit.

**CONTACTS**

20 contacts  
User to specify combination of make & break contacts

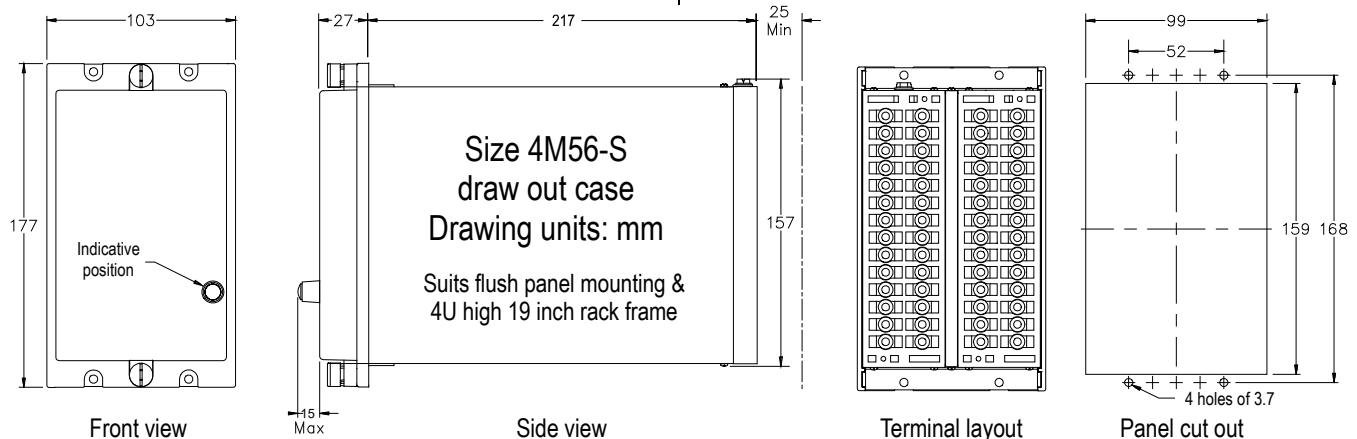

**Ordering Codes**

Generate the required ordering code as follows:  
e.g. 6RJ24-20-D-10M10B

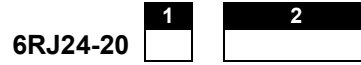

**1 NOMINAL OPERATE VOLTAGE**

A	24V DC	E	125V D
B	32V DC	G	220V DC
C	48V DC	H	240V DC
D	110V DC	F	250V DC

**3 CONTACT ARRANGEMENT** (Not to exceed maximum)

Specify the number of "MAKES" followed by M; i.e. 10M  
Specify the number of "BREAKS" followed by B; i.e. 10B

**6R RELAY CONTACT RATINGS**

**Make & Carry Continuously**

3,000 VA AC resistive with maximums of 660V & 12A  
3,000 W DC resistive with maximums of 660V & 12A

**Make & Carry for 3 Seconds**

7,500 VA AC resistive with maximums of 660V & 30A  
7,500 W DC resistive with maximums of 660V & 30A

**AC Break Capacity**

3,000 VA AC resistive with maximums of 660V & 12A

**DC Break Capacity (Amps)**

Voltage		24V	48V	125V	250V
Resistive rating		12	2	0.5	0.25
L/R=40ms	Maximum break	12	1	0.25	0.15

**INSULATION WITHSTAND** in accordance with IEC 255-5:

2KV RMS & 1.2/50 5KV impulse between:

- ◆ all terminals & frame
- ◆ each contact group
- ◆ all contacts & coil

**CASE SIZE**

4M56-S draw out case



**RMS Mors Smitt**  
A *Wabtec* Company

---

**RMS Mors Smitt**  
19 Southern Court  
Keysborough, VIC 3173, Australia  
Tel: +61 (0)3 8544 1200  
sales.rms@wabtec.com



**RMS Mors Smitt**  
A *Wabtec* Company

**Wabtec Netherlands B.V.**  
Darwinstraat 10  
6718 XR Ede, Netherlands  
Tel: +31 (0)88 600 4500  
wnl\_salessupport@wabtec.com



Visit [www.morssmitt.com/rms](http://www.morssmitt.com/rms) for the latest product information.  
Due to RMS continuous product improvement policy this information is subject to change without notice

