

High Speed Tripping Relay 6RJ23-20

For fast and secure multi-trip protection applications.

- > High speed operation
- > High burden
- > Hand reset contacts & flag
- > High security mechanical lock out
- > 20 contacts
- > Equivalent function to MVAJ23
- > 2HSM514 specification



Description

The 6RJ23 is a high burden hand reset lock out relay suitable for application in high security circuit breaker tripping circuits & in particular where the initiating contact may be remote from the relay. The high burden may also allow the satisfactory operation of external series elements.

The 6RJ23 has a high burden to provide immunity to capacitance discharge currents & power to the coil is cut off at operation or is economized to a low figure to provide thermal protection.

High burden tripping relays are designed to withstand the 10uF capacitor discharge test such that the relay will not operate when a 10uF capacitor charged to 120% of nominal operating voltage is applied across the coil of the relay.

The high speed relay coil is automatically protected from thermal damage by a series cut throat contact once the relay contacts have picked up & latched.

The contacts & trip flag indication operate on application of a control voltage. The contacts & flag are reset using the front panel push button.



Cross Reference List

RMS	Alstom	Reyrolle	Contacts	Functional Description
6RJ23-5	MVAJ23, MVAJ053	TR221	5	High burden high speed trip relay Hand reset contacts & flag
6RJ23-10	MVAJ23, MVAJ103	TR221	10	
6RJ23-20	MVAJ203	TRA221	20	

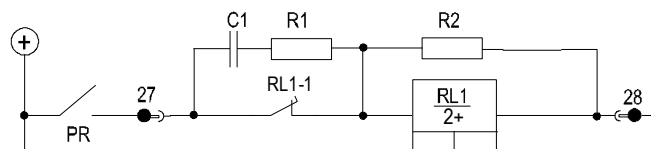

6RJ23

Relay Circuit Diagram

Contact Operation

Latching contacts with the front panel hand reset button.
 Holding the reset button in the depressed position with a trip signal is applied may result in thermal damage to the high speed operate coil.

Flag Operation

Drops on coil energisation.
 Hand reset with the contacts.

AC Voltages

Standard 6RJ relays are not intended for operation with AC voltages. Application of continuous AC voltage below the pick up level will cause excessive power dissipation in the capacitor discharge resistor & likely result in thermal damage to the device.

Contacts

20 Contacts
 User to specify combination of make & break contacts

Operating Burden

High burden relays	150W Maximum
--------------------	--------------

Operated Burden

Hand reset contacts	Zero
---------------------	------

Coil Thermal Rating

Operating Circuit	Withstand 120% at Nominal Voltage Continuously
-------------------	--

Operating Time

<10ms at nominal operating voltage

Operating Voltage Range

Between 65% and 120% of nominal rated operating voltage

Note: The 65% of nominal value allows for correct operation of the tripping systems even when there is a loss of battery charger supply for considerable periods.

To ensure guaranteed operation at 65% of nominal voltage the relay is manufactured to operate at a lower level to guarantee operation if the voltage falls to 65% of nominal voltage. Consequently, it will be found that these relays will operate below 65% of nominal voltage, this is normal and correct and does not affect relay stability due to the high burden characteristics of the relay.

The 65% of nominal voltage figure does not indicate the relay pickup voltage.

Nominal Operating Voltages

24, 32, 48, 110, 125, 220, 240 & 250V DC available
--

Minimum Operating Current

High Burden Relays	100mA
--------------------	-------

Contact Ratings

Make and carry Continuous	3,000 VA AC resistive			
	3,000 W DC resistive			
Make and carry for 3s	Limited at both 660 V and 12 A			
	7,500 VA AC resistive			
AC break capacity	7,500 W DC resistive			
	Limited at both 660 V and 30 A			
DC break capacity (Amps)	3,000 VA AC resistive			
	Limited at both 660 V and 12 A			
Voltage	24V	48V	125V	250V
Resistive Rating	12	2	0.5	0.3
Inductive Rating L/R=40ms	12	1	0.25	0.15

Insulation

Standard	IEC 60255-5
Category	3
Between all terminals and earth	2.0 kV rms for 60 s
Between Independent Circuits	2.0 kV rms for 60 s
Across Normally Open Contacts	1.0 kV rms for 60 s
3 Positive and 3 negative Impluses:	
Between all terminals and earth	5.0 kV 1.2/50 μ s 0.5 J
Between Independent circuits	5.0 kV 1.2/50 μ s 0.5 J

Capacitor Discharge

Standard	ENA TS 48-4 2010 ISSUE 4
Nominal voltage	Capacitor discharge test compliance
32 V dc	Not applicable
48 V dc	
110 V dc	No mal op. for Capacitor discharge:
125 V dc	C = 10 μ F
230 V dc *	V = 120% of Vnominal
240 V dc *	(* 275V Maximum)
250 V dc *	

Temperature

Standard	IEC 60068-2-1/2
Operating Range	-10 to +55 degrees Celsius
Storage Range	-25 to +70 degrees Celsius

Humidity

Standard	IEC 60068-2-78
Operating Range	40 degrees Celsius and 93% RH non condensing

Enclosure protection

Standard	IEC 60529
Installed	IP5x

Vibration - Sinusoidal

Standard	IEC 60255-21-1 Class I	
Vibration Response	0.5gn	$\leq 5\%$
Vibration Endurance	1.0gn	$\leq 5\%$

Shock and Bump

Standard	IEC 60255-21-2 Class I	
Shock Response	5gn, 11ms	$\leq 5\%$
Shock Withstand	15gn, 11ms	$\leq 5\%$
Bump Test	10gn, 16ms	$\leq 5\%$

Seismic

Standard	IEC 60255-21-3 Class I	
Seismic Response Type	Level	Variation
Horizontal	1 gn	$\leq 5\%$
Vertical	0.5 gn	$\leq 5\%$

Mechanical Classification

Durability - 0.1 Hz maximum repetition rate	$>10^5$ operations at no load
	$>10^4$ operations at full load

6RJ23-20 – Wiring Schedule

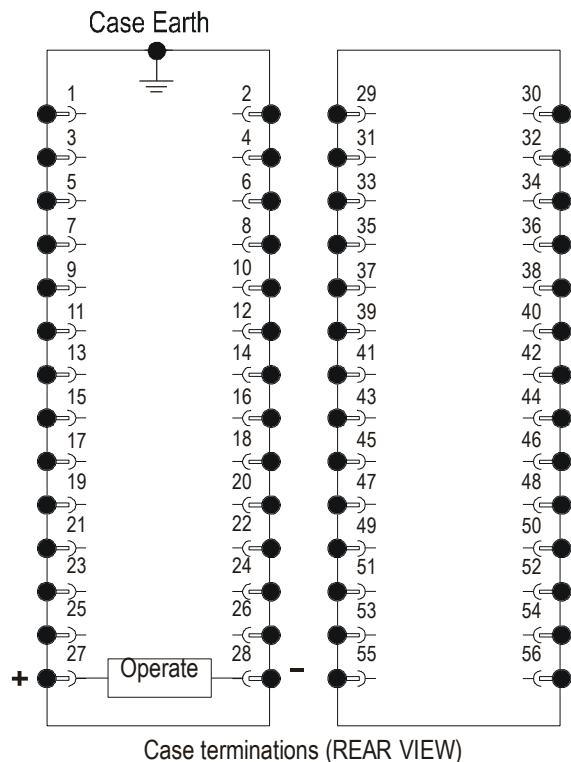

6RJ23-20 Terminal Numbers																				
	1	2	5	6	9	10	13	14	17	18	21	22	29	30	33	34	37	38	41	42
	&	&	&	&	&	&	&	&	&	&	&	&	&	&	&	&	&	&	&	&
	3	4	7	8	11	12	15	16	19	20	23	24	31	32	35	36	39	40	43	44
Contacts	1	2	3	4	5	6	7	8	9	10	11	12	13	14	15	16	17	18	19	20
20M	M	M	M	M	M	M	M	M	M	M	M	M	M	M	M	M	M	M	M	M
19M+1B	M	M	M	M	M	M	M	M	M	M	M	M	M	M	M	M	M	M	M	B
18M+2B	M	M	M	M	M	M	M	M	M	M	M	M	M	M	M	M	M	M	B	B
17M+3B	M	M	M	M	M	M	M	M	M	M	M	M	M	M	M	M	M	B	B	B
16M+4B	M	M	M	M	M	M	M	M	M	M	M	M	M	M	M	M	B	B	B	B
15M+5B	M	M	M	M	M	M	M	M	M	M	M	M	M	M	M	B	B	B	B	B
14M+6B	M	M	M	M	M	M	M	M	M	M	M	M	M	M	B	B	B	B	B	B
13M+7B	M	M	M	M	M	M	M	M	M	M	M	M	B	B	B	B	B	B	B	B
12M+8B	M	M	M	M	M	M	M	M	M	M	M	B	B	B	B	B	B	B	B	B
11M+9B	M	M	M	M	M	M	M	M	M	M	B	B	B	B	B	B	B	B	B	B
10M+10B	M	M	M	M	M	M	M	M	M	B	B	B	B	B	B	B	B	B	B	B
9M+11B	M	M	M	M	M	M	M	M	B	B	B	B	B	B	B	B	B	B	B	B
8M+12B	M	M	M	M	M	M	M	B	B	B	B	B	B	B	B	B	B	B	B	B
7M+13B	M	M	M	M	M	M	B	B	B	B	B	B	B	B	B	B	B	B	B	B
6M+14B	M	M	M	M	M	B	B	B	B	B	B	B	B	B	B	B	B	B	B	B
5M+15B	M	M	M	M	B	B	B	B	B	B	B	B	B	B	B	B	B	B	B	B
4M+16B	M	M	M	M	B	B	B	B	B	B	B	B	B	B	B	B	B	B	B	B
3M+17B	M	M	M	B	B	B	B	B	B	B	B	B	B	B	B	B	B	B	B	B
2M+18B	M	M	B	B	B	B	B	B	B	B	B	B	B	B	B	B	B	B	B	B
1M+19B	M	B	B	B	B	B	B	B	B	B	B	B	B	B	B	B	B	B	B	B
20B	B	B	B	B	B	B	B	B	B	B	B	B	B	B	B	B	B	B	B	B

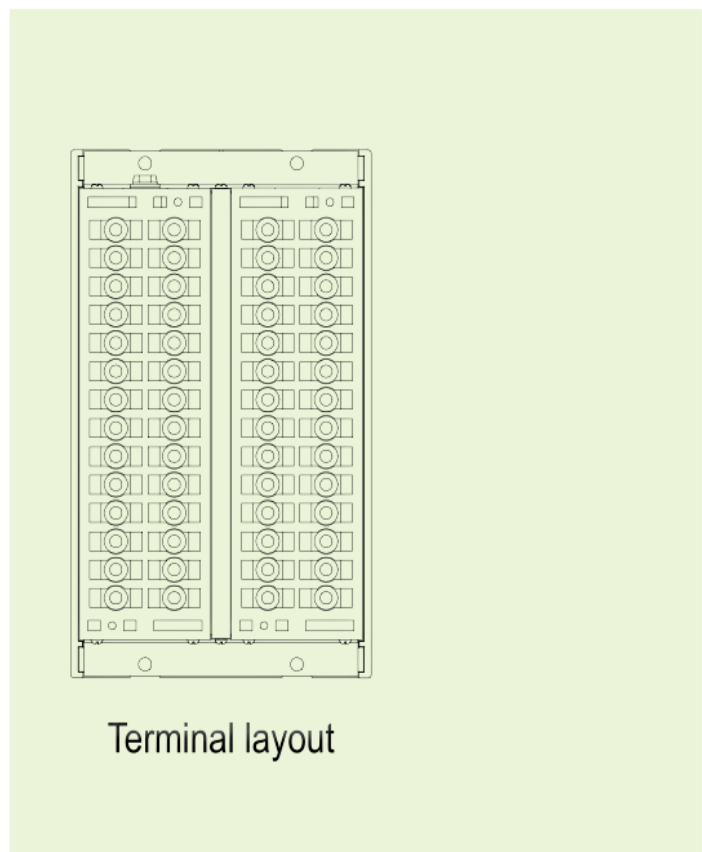
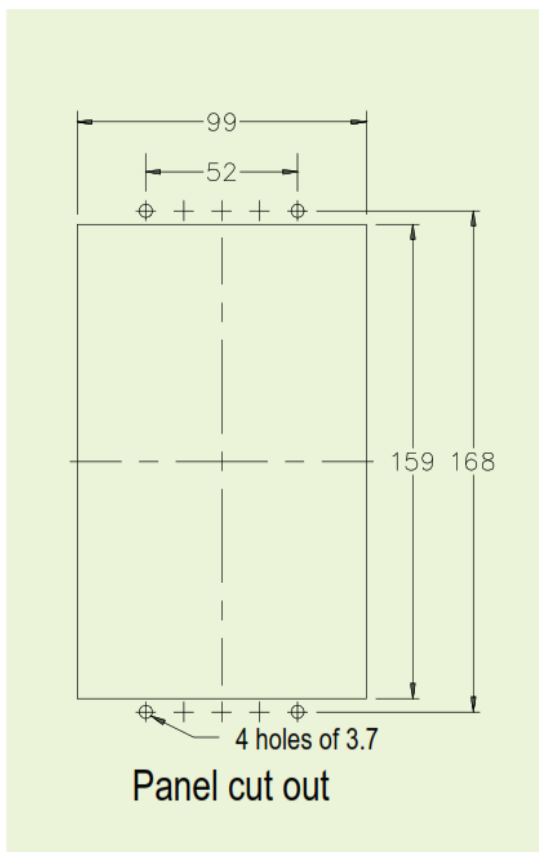
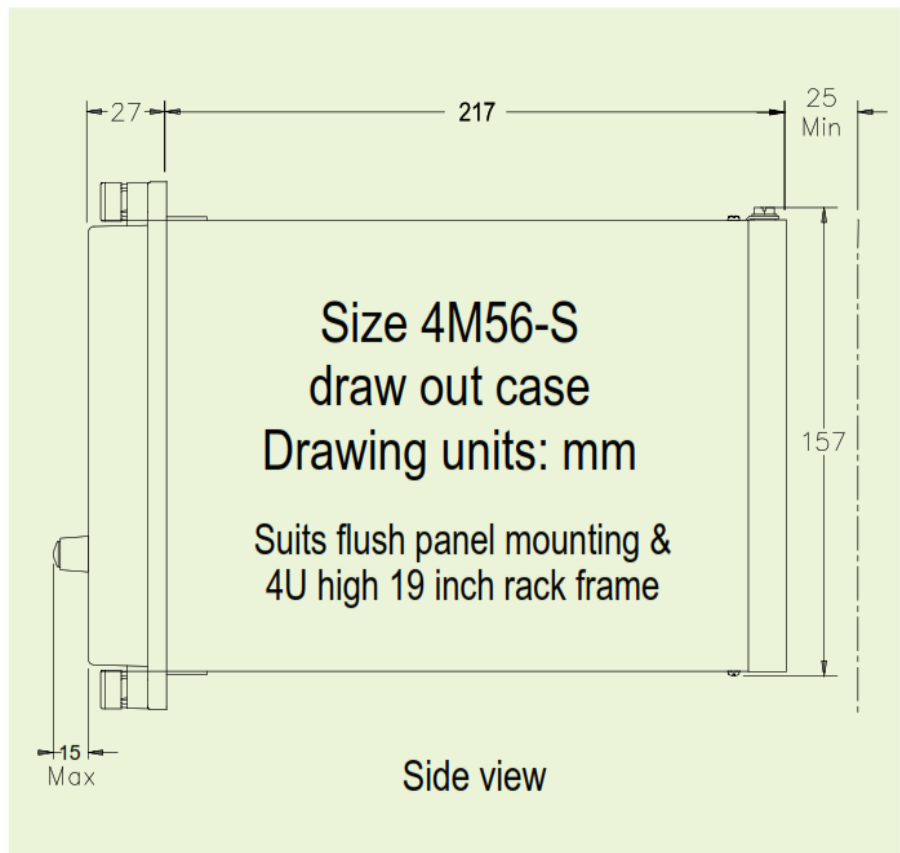
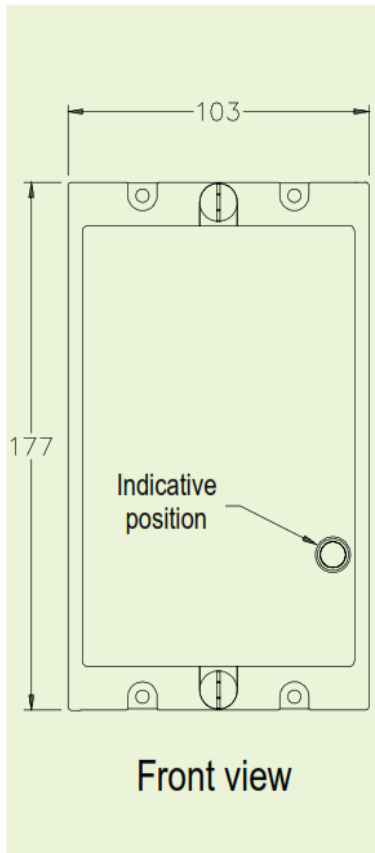

Relay Order Code

6RJ23-20		
Nominal Operate Voltage	A	24V DC
	B	32V DC
	C	48V DC
	D	110V DC
	E	125V DC
	F	250V DC
	G	220V DC
	H	240V DC
Contact Arrangement	0 M	Specify the number of "MAKES" followed by M
	0 B	Specify the number of "BREAKS" followed by B

Example Ordering Code: **6RJ23-20-D-8M 12B**



RMS Mors Smitt
19 Southern Court
Keysborough, VIC 3173, Australia
Tel: +61 (0)3 8544 1200
sales.rms@wabtec.com



Wabtec Netherlands B.V.
Darwinstraat 10
6718 XR Ede, Netherlands
Tel: +31 (0)88 600 4500
wnl_salessupport@wabtec.com

