

High Speed Tripping Relay 6RJ21

For fast and secure multi-trip protection applications.

- > High speed operation
- > High burden
- > Self reset contacts
- > Hand reset flag indicator
- > 5 or 10 contacts
- > Equivalent function to MVAJ21
- > 2HSM512 specification

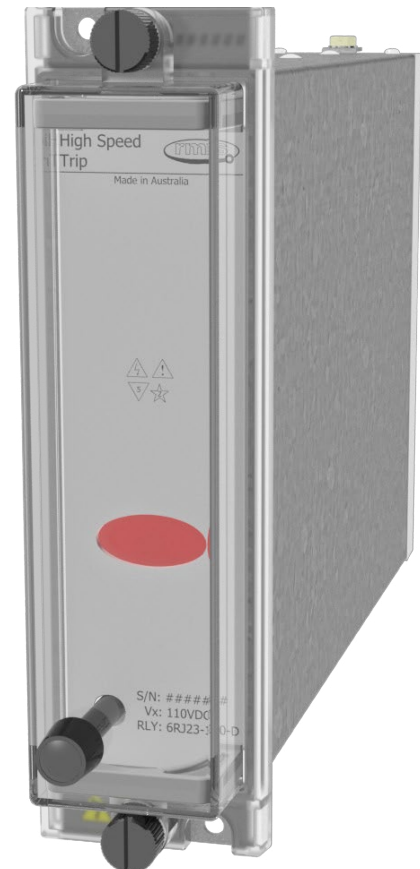

Description

The 6RJ21 is a high burden self reset tripping relay suitable for application in high security circuit breaker tripping circuits & in particular where the initiating contact may be remote from the relay. The high burden may also allow the satisfactory operation of external series elements.

The 6RJ21 has a high burden to provide immunity to capacitance discharge currents. Power to the coil is economized to a low figure to provide thermal protection.

High burden tripping relays are designed to withstand the 10uF capacitor discharge test such that the relay will not operate when a 10uF capacitor charged to 120% of nominal operating voltage is applied across the coil of the relay.

The contacts & trip flag indication operate on application of a control voltage. Contacts are reset upon removal of the control voltage. The flag is reset using the front panel push button provided the contacts are in the reset position.



Cross Reference List

RMS	Alstom	Reyrolle	Contacts	Functional Description
6RJ21-5	MVAJ21, MVAJ051	TR212	5	High burden high speed trip relay
6RJ21-10	MVAJ21, MVAJ101	TR212	10	Self reset contacts
6RJ21-20	MVAJ201	TRA212	20	Hand reset flag

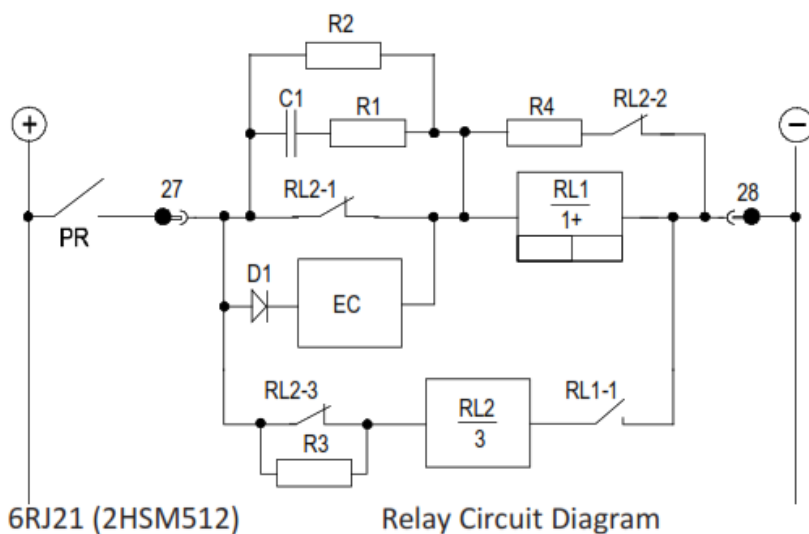

Contact Operation

Self reset contacts. N/O contacts pick up when the relay is energised & drop out when the operate voltage is removed.

Flag Operation

Drops on coil energisation.
Hand reset when the contacts are in the reset position.

AC Voltages

Standard 6RJ relays are not intended for operation with AC voltages. Application of continuous AC voltage below the pick up level will cause excessive power dissipation in the capacitor discharge resistor & likely result in thermal damage to the device.

Contacts

5 or 10 contacts
User to specify combination of make & break contacts
For 20 contact version refer to the 6RJ21-20 Technical Bulletin

Operating Burden

High burden relays	150W Maximum
--------------------	--------------

Operated Burden

Self reset contacts	6W Maximum
---------------------	------------

Coil Thermal Rating

Operating Circuit	Withstand 120% at Nominal Voltage Continuously
-------------------	--

Operating Time

<10ms at nominal operating voltage

Operating Voltage Range

Between 65% and 120% of nominal rated operating voltage

Note: The 65% of nominal value allows for correct operation of the tripping systems even when there is a loss of battery charger supply for considerable periods.

To ensure guaranteed operation at 65% of nominal voltage the relay is manufactured to operate at a lower level to guarantee operation if the voltage falls to 65% of nominal voltage. Consequently, it will be found that these relays will operate below 65% of nominal voltage, this is normal and correct and does not affect relay stability due to the high burden characteristics of the relay.

The 65% of nominal voltage figure does not indicate the relay pickup voltage.

Nominal Operating Voltages

24, 32, 48, 110, 125, 220, 240 & 250V DC available
--

Minimum Operating Current

High Burden Relays	100mA
--------------------	-------

Contact Ratings

Operating Voltage	Voltage free			
Isolation across open contacts	1 kV rms			
Make and carry: Continuous	3,000 VA AC resistive			
	3,000 W DC resistive			
Make and carry for 3s	Limited at both 660 V and 12 A			
	7,500 VA AC resistive			
AC break capacity	7,500 W DC resistive			
	Limited at both 660 V and 30 A			
DC break capacity (Amps)	3,000 VA AC resistive			
	Limited at both 660 V and 12 A			
Voltage	24V	48V	125V	300V
Resistive Rating	12	2	0.5	0.3
Inductive Rating L/R=40ms	12	1	0.25	0.15

Insulation

Standard	IEC 60255-5
Category	3
Between all terminals and earth	2.0 kV rms for 60 s
Between Independent Circuits	2.0 kV rms for 60 s
Across Normally Open Contacts	1.0 kV rms for 60 s
3 Positive and 3 negative Impluses:	
Between all terminals and earth	5.0 kV 1.2/50 μ s 0.5 J
Between Independent circuits	5.0 kV 1.2/50 μ s 0.5 J

Capacitor Discharge

Standard	ENA TS 48-4 2010 ISSUE 4
Nominal voltage	Capacitor discharge test compliance
32 V dc	Not applicable
48 V dc	
110 V dc	No mal op. for Capacitor discharge: C = 10 μ F
125 V dc	V = 120% of Vnominal
230 V dc *	(* 275V Maximum)
240 V dc *	
250 V dc *	

Temperature

Standard	IEC 60068-2-1/2
Operating Range	-10 to +55 degrees Celsius
Storage Range	-25 to +70 degrees Celsius

Humidity

Standard	IEC 60068-2-78
Operating Range	40 degrees Celsius and 93% RH non condensing

Enclosure protection

Standard	IEC 60529
Installed	IP5x

Vibration - Sinusoidal

Standard	IEC 60255-21-1 Class I
Vibration Response	0.5gn \leq 5%
Vibration Endurance	1.0gn \leq 5%

Shock and Bump

Standard	IEC 60255-21-2 Class I
Shock Response	5gn, 11ms \leq 5%
Shock Withstand	15gn, 11ms \leq 5%
Bump Test	10gn, 16ms \leq 5%

Seismic

Standard	IEC 60255-21-3 Class 2
Seismic Response Type	Level Variation
Horizontal	2.0 gn \leq 5%
Vertical	1.0 gn \leq 5%

Mechanical Classification

Durability - 0.1 Hz maximum repetition rate	>10 ⁵ operations at no load >10 ⁴ operations at full load
---	--

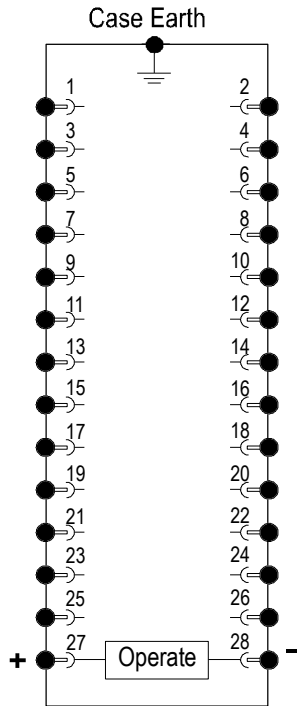

Case terminations
(REAR VIEW)

6RJ21-5 Terminal Numbers

Contacts	1-3	2-4	5-7	6-8	9-11
5M	M	M	M	M	M
4M+1B	M	M	M	M	B
3M+2B	M	M	M	B	B
2M+3B	M	M	B	B	B
1M+4B	M	B	B	B	B
5B	B	B	B	B	B

6RJ21-10 Terminal Numbers

Contacts	1-3	2-4	5-7	6-8	9-11	10-12	13-15	14-16	17-19	18-20
10M	M	M	M	M	M	M	M	M	M	M
9M+1B	M	M	M	M	M	M	M	M	M	B
8M+2B	M	M	M	M	M	M	M	M	B	B
7M+3B	M	M	M	M	M	M	M	B	B	B
6M+4B	M	M	M	M	M	M	B	B	B	B
5M+5B	M	M	M	M	M	B	B	B	B	B
4M+6B	M	M	M	M	B	B	B	B	B	B
3M+7B	M	M	M	B	B	B	B	B	B	B
2M+8B	M	M	B	B	B	B	B	B	B	B
1M+9B	M	B	B	B	B	B	B	B	B	B
10B	B	B	B	B	B	B	B	B	B	B

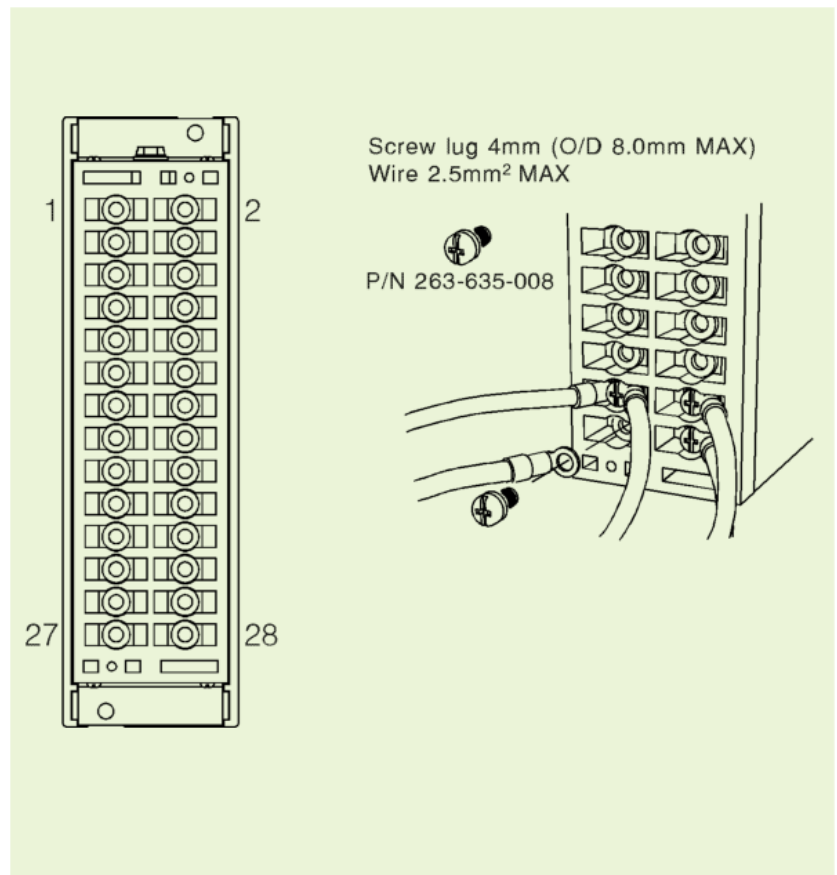
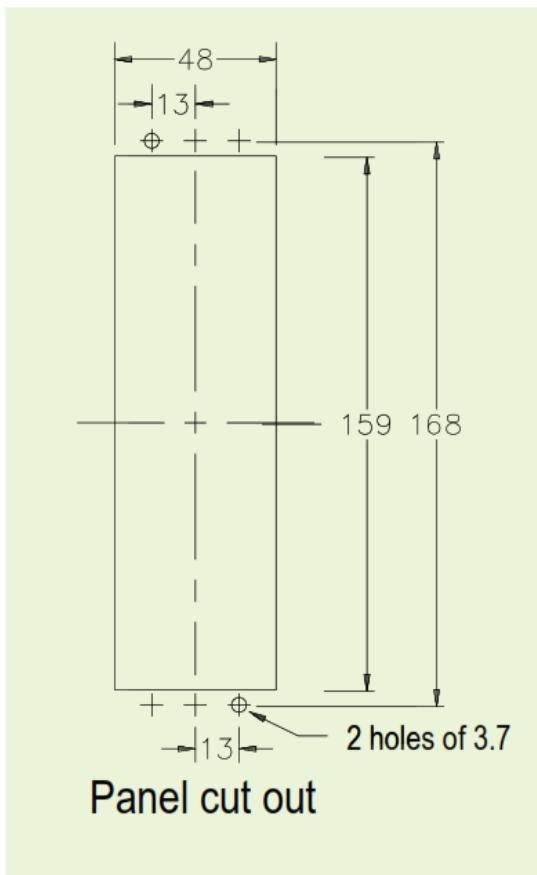
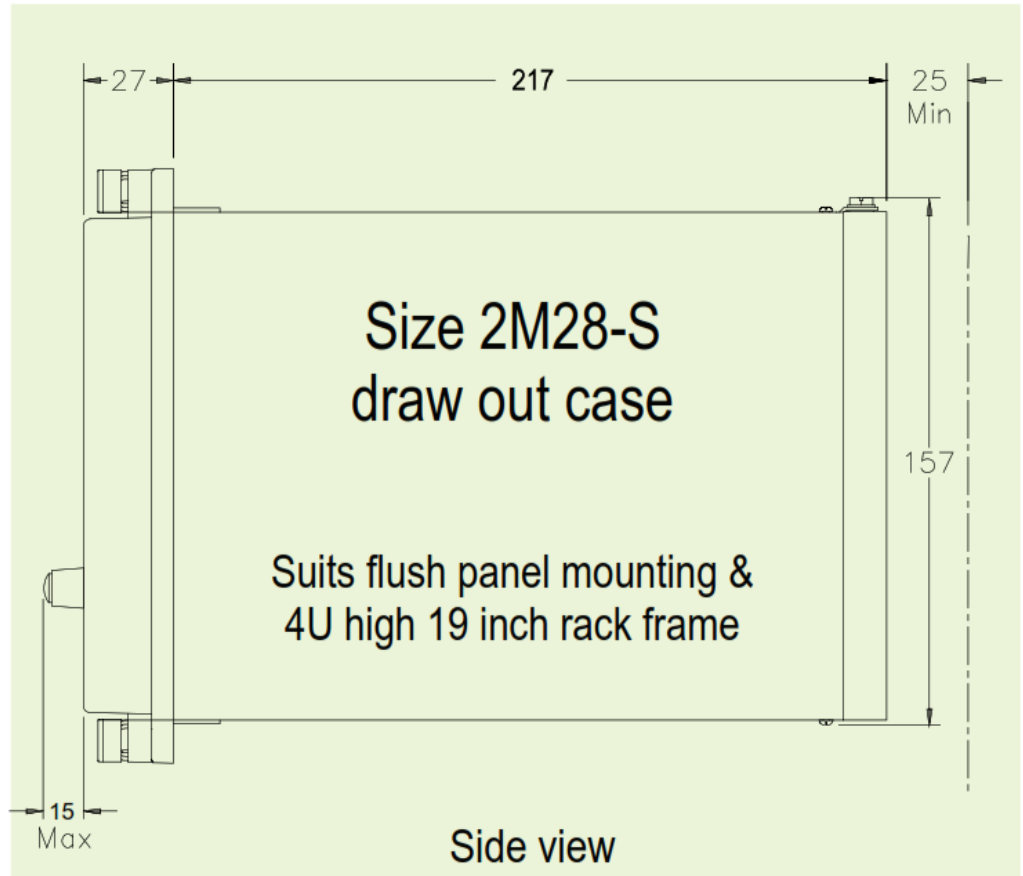
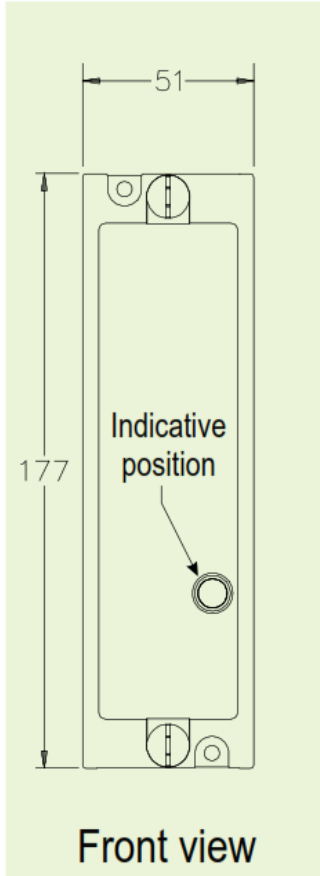

Relay Order Code

6RJ21 -		<input type="text"/>	<input type="text"/>	<input type="text"/>
Number of Contacts	5	5 Contacts		
	10	10 Contacts		
Nominal Operate Voltage	A	24V DC		
	B	32V DC		
	C	48V DC		
	D	110V DC		
	E	125V DC		
	F	250V DC		
	G	220V DC		
	H	240V DC		
Contact Arrangement	0 M	Specify the number of "MAKES" followed by M		
	0 B	Specify the number of "BREAKS" followed by B		

Example Ordering Code: **6RJ21-10-D-8M 2B**

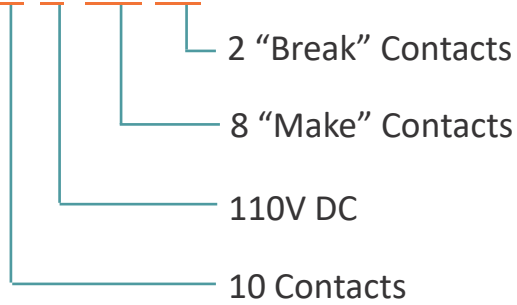

RMS Mors Smitt
19 Southern Court
Keysborough, VIC 3173, Australia
Tel: +61 (0)3 8544 1200
sales.rms@wabtec.com



Wabtec Netherlands B.V.
Darwinstraat 10
6718 XR Ede, Netherlands
Tel: +31 (0)88 600 4500
wnl_salessupport@wabtec.com

