

## Features

- High speed operation
- Low burden
- Hand & electrical reset contacts
- Independent hand reset flag
- 5 or 10 contacts
- Equivalent function to MVAJ15
- 2HSM509 specification

## Application

The effect of a fault on a power system is dependent on the speed with which the fault can be detected & isolated. The 6RJ Series multi-contact high-speed trip relays are used for this isolating function providing simultaneous tripping outputs.

A high speed coil provides fast operation (<10ms at nominal voltage), with specially constructed anti bounce buffers ensuring effective damping of the contacts to avoid excessive bounce.

**6RJ15**

**Low Burden Hand / Electrical Reset Trip & Lockout Relay**

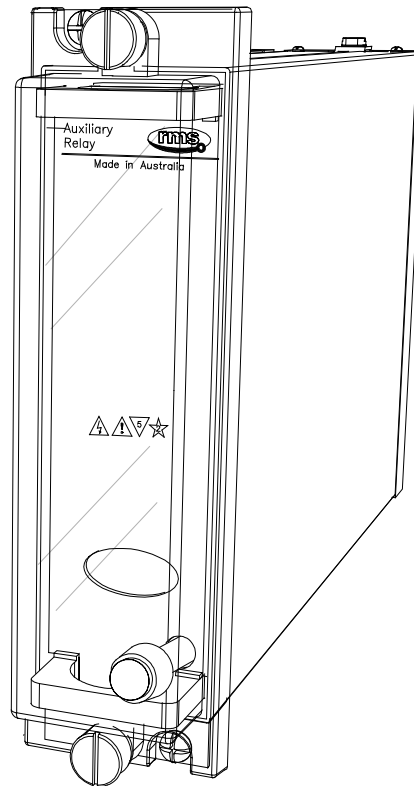

2M28 draw out case

## Low Burden 5 & 10 Contact Tripping Relay

The 6RJ15 is a low burden hand & electrical reset high speed tripping relay suitable for applications where immunity to capacitance discharge & high minimum operation currents is not required.

The high speed relay coil is automatically protected from thermal damage by a series cut throat contact once the relay contacts have picked up & latched.

The contacts can be reset using the front panel reset push button or via the electrical reset input. The electrical reset coil is automatically protected from thermal damage by a series cut throat contact once the relay contacts have been reset.

The trip flag can only be reset via the independent front panel reset push button after the contacts have been reset. This feature allows the flag indication to be maintained as a record of trip operation even if the contacts have been electrically reset by remote control or by an auto reclose scheme.

The 6RJ13 version may be specified where the contacts & flag are reset simultaneously.

## Terminal Wiring

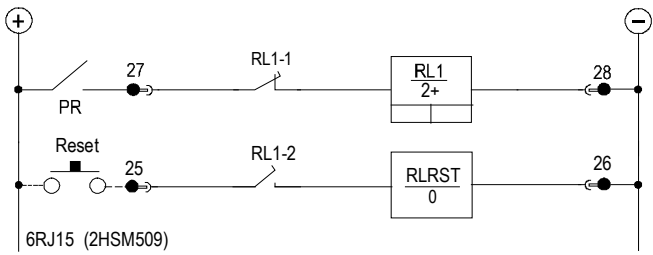

Relay circuit diagram

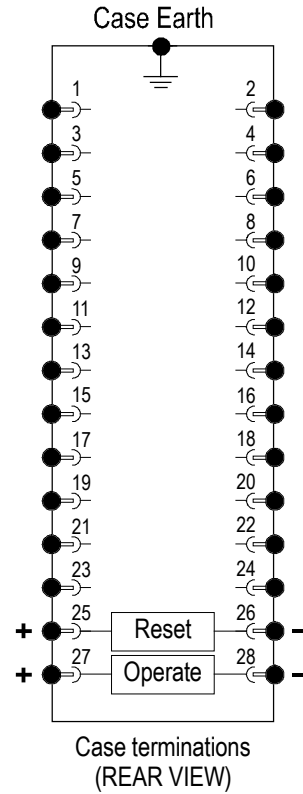

Case terminations  
(REAR VIEW)

6RJ15-5 Terminal Numbers					
Contacts	1-3	2-4	5-7	6-8	9-11
5M	M	M	M	M	M
4M+1B	M	M	M	M	B
3M+2B	M	M	M	B	B
2M+3B	M	M	B	B	B
1M+4B	M	B	B	B	B
5B	B	B	B	B	B

6RJ15-10 Terminal Numbers										
Contacts	1-3	2-4	5-7	6-8	9-11	10-12	13-15	14-16	17-19	18-20
10M	M	M	M	M	M	M	M	M	M	M
9M+1B	M	M	M	M	M	M	M	M	M	B
8M+2B	M	M	M	M	M	M	M	M	B	B
7M+3B	M	M	M	M	M	M	M	B	B	B
6M+4B	M	M	M	M	M	M	B	B	B	B
5M+5B	M	M	M	M	M	B	B	B	B	B
4M+6B	M	M	M	M	B	B	B	B	B	B
3M+7B	M	M	M	B	B	B	B	B	B	B
2M+8B	M	M	B	B	B	B	B	B	B	B
1M+9B	M	B	B	B	B	B	B	B	B	B
10B	B	B	B	B	B	B	B	B	B	B

**OPERATING BURDEN** (Burden during pick up at nominal)  
 Low burden relays: 50W Maximum  
 Reset coils: 40W Maximum

**OPERATED BURDEN**  
 Hand reset contacts: Zero  
 Reset coils: Zero

**COIL THERMAL RATING**  
 The operate circuit is designed to withstand continuous application of 120% of nominal voltage. The high speed operate coil element (50 watt max.) has a thermal rating of 30 seconds, however this is protected by use of the instantaneous series cut-off contact arrangement.

**OPERATING TIME**  
 Less than 10ms at nominal rated operating voltage.

**CONTACT OPERATION**  
 Latching contacts with front panel hand reset button & reset coil for remote electrical reset. Continuous application of a control voltage to both the trip & reset inputs must be avoided otherwise thermal damage to both coils may occur. Likewise holding the reset button in the depressed position with a trip signal is applied may result in thermal damage to the high speed operate coil.

**FLAG OPERATION**  
 Drops on coil energisation.  
 Independent hand reset button.  
 Contacts must be in the reset position before the flag can be reset.

**OPERATING VOLTAGE RANGE**  
 Guaranteed operation between 65% & 120% of nominal rated operating voltage.

Note: The 65% of nominal value allows for correct operation of the tripping systems even when there is a loss of battery charger supply for considerable periods.

To ensure guaranteed operation at 65% of nominal voltage the relay is manufactured to operate at a lower level to guarantee operation if the voltage falls to 65% of nominal voltage. Consequently, it will be found that these relays will operate below 65% of nominal voltage, this is normal and correct.

The 65% of nominal voltage figure does not indicate the relay pickup voltage.

**AC VOLTAGES**  
 Standard 6RJ relays are not intended for operation with AC voltages. Application of continuous AC voltage below the pick up level will cause excessive power dissipation in the capacitor discharge resistor & likely result in thermal damage to the device.

**NOMINAL OPERATING VOLTAGES**  
 24, 32, 48, 110, 125, 220, 240 & 250V DC available.

**MINIMUM OPERATING CURRENT**  
 Low burden relays: 50mA

**ELECTRICAL RESET**  
 Operate voltage: As per specified operate voltage.  
 Reset cut off: Instantaneous with main relay reset.

Continuous application of both the high speed pick up coil & the reset coil (or contact reset button), will defeat the cut throat contact & result in overheating & thermal damage to both coils & associated circuit.

**CONTACTS**  
 5 or 10 contacts  
 User to specify combination of make & break contacts

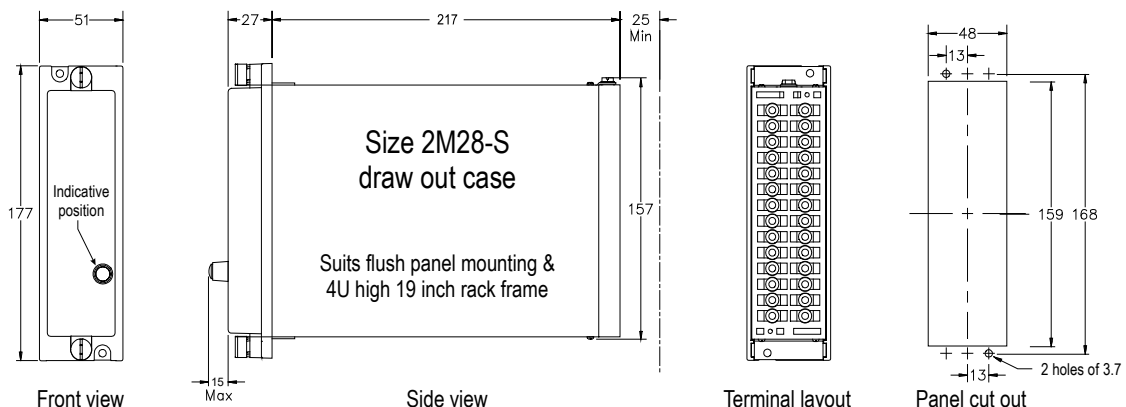

## Ordering Codes

Generate the required ordering code as follows:  
 e.g. 6RJ15-10-D-8M2B

6RJ15 

1
---

2
---

3
---

**1 NUMBER OF CONTACTS**

5 5 contacts  
 10 10 contacts

**2 NOMINAL OPERATE VOLTAGE**

A 24V DC	E 125V D
B 32V DC	G 220V DC
C 48V DC	H 240V DC
D 110V DC	F 250V DC

**3 CONTACT ARRANGEMENT** (Not to exceed maximum)

Specify the number of "MAKES" followed by M; i.e. 8M  
 Specify the number of "BREAKS" followed by B; i.e. 2B

**6R RELAY CONTACT RATINGS**

**Make & Carry Continuously**  
 3,000 VA AC resistive with maximums of 660V & 12A  
 3,000 W DC resistive with maximums of 660V & 12A

**Make & Carry for 3 Seconds**  
 7,500 VA AC resistive with maximums of 660V & 30A  
 7,500 W DC resistive with maximums of 660V & 30A

**AC Break Capacity**  
 3,000 VA AC resistive with maximums of 660V & 12A

**DC Break Capacity (Amps)**

Voltage	24V	48V	125V	250V	
Resistive rating	12	2	0.5	0.25	
L/R=40ms	Maximum break	12	1	0.25	0.15

**INSULATION WITHSTAND** in accordance with IEC 255-5:  
 2KV RMS & 1.2/50 5KV impulse between:

- ◆ all terminals & frame
- ◆ each contact group
- ◆ all contacts & coil

**CASE SIZE**  
 2M28-S draw out case

---

**RMS Mors Smitt**  
19 Southern Court  
Keysborough, VIC 3173, Australia  
Tel: +61 (0)3 8544 1200  
[sales.rms@wabtec.com](mailto:sales.rms@wabtec.com)



**Wabtec Netherlands B.V.**  
Darwinstraat 10  
6718 XR Ede, Netherlands  
Tel: +31 (0)88 600 4500  
[wnl\\_salesupport@wabtec.com](mailto:wnl_salesupport@wabtec.com)



Visit [www.morssmitt.com/rms](http://www.morssmitt.com/rms) for the latest product information.  
Due to RMS continuous product improvement policy this information is subject to change without notice