

**6RJ11**

**Low Burden Self Reset High Speed Trip Relay**

**Features**

- High speed operation
- Low burden
- Self reset contacts
- Hand reset flag indicator
- 5 or 10 contacts
- Equivalent function to MVAJ11
- 2HSM502 specification

**Application**

The effect of a fault on a power system is dependent on the speed with which the fault can be detected & isolated. The 6RJ Series multi-contact high-speed trip relays are used for this isolating function providing simultaneous tripping outputs.

A high speed coil provides fast operation (<10ms at nominal voltage), with specially constructed anti bounce buffers ensuring effective damping of the contacts to avoid excessive bounce.

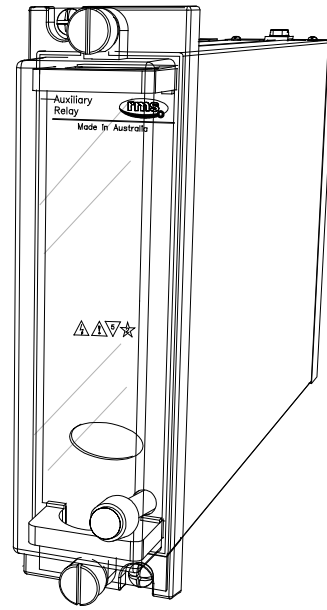

2M28 draw out case

**Low Burden 5 & 10 Contact Tripping Relay**

The 6RJ11 is a low burden self reset high speed tripping relay suitable for applications where immunity to capacitance discharge & high minimum operation currents is not required.

The high speed relay coil is automatically protected from thermal damage by an integrated economizing circuit once the relay contacts have picked up & latched.

The contacts & trip flag indication operate on application of a control voltage. Contacts are reset upon removal of the control voltage. The flag is reset using the front panel push button provided the contacts are in the reset position.

## Terminal Wiring

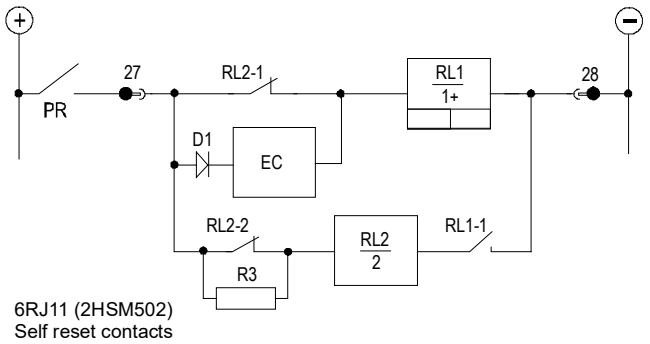

Relay circuit diagram

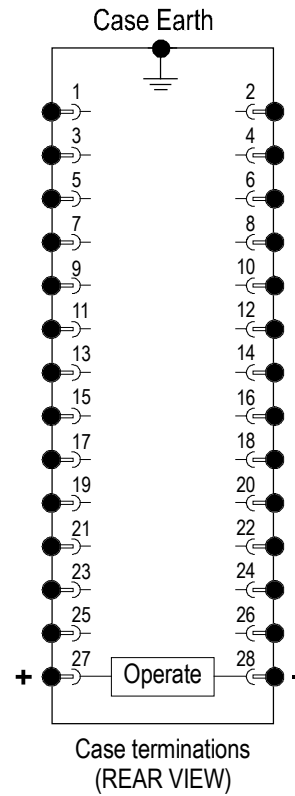

**6RJ11-5 Terminal Numbers**

| Contacts | 1-3 | 2-4 | 5-7 | 6-8 | 9-11 |
|----------|-----|-----|-----|-----|------|
| 5M       | M   | M   | M   | M   | M    |
| 4M+1B    | M   | M   | M   | M   | B    |
| 3M+2B    | M   | M   | M   | B   | B    |
| 2M+3B    | M   | M   | B   | B   | B    |
| 1M+4B    | M   | B   | B   | B   | B    |
| 5B       | B   | B   | B   | B   | B    |

**6RJ11-10 Terminal Numbers**

| Contacts | 1-3 | 2-4 | 5-7 | 6-8 | 9-11 | 10-12 | 13-15 | 14-16 | 17-19 | 18-20 |
|----------|-----|-----|-----|-----|------|-------|-------|-------|-------|-------|
| 10M      | M   | M   | M   | M   | M    | M     | M     | M     | M     | M     |
| 9M+1B    | M   | M   | M   | M   | M    | M     | M     | M     | M     | B     |
| 8M+2B    | M   | M   | M   | M   | M    | M     | M     | M     | B     | B     |
| 7M+3B    | M   | M   | M   | M   | M    | M     | M     | B     | B     | B     |
| 6M+4B    | M   | M   | M   | M   | M    | M     | B     | B     | B     | B     |
| 5M+5B    | M   | M   | M   | M   | M    | B     | B     | B     | B     | B     |
| 4M+6B    | M   | M   | M   | M   | B    | B     | B     | B     | B     | B     |
| 3M+7B    | M   | M   | M   | B   | B    | B     | B     | B     | B     | B     |
| 2M+8B    | M   | M   | B   | B   | B    | B     | B     | B     | B     | B     |
| 1M+9B    | M   | B   | B   | B   | B    | B     | B     | B     | B     | B     |
| 10B      | B   | B   | B   | B   | B    | B     | B     | B     | B     | B     |

**OPERATING BURDEN** (Burden during pick up at nominal)  
Low burden relays: 50W Maximum

**OPERATED BURDEN** (Burden after pick up at nominal)  
Self reset contacts: 6W Maximum

**COIL THERMAL RATING**

All operate circuits are designed to withstand continuous application of 120% of nominal voltage. The high speed operate coil element (50 watt max.) has a thermal rating of 30 seconds, however this is protected by use of the series economy coil.

**CONTACT OPERATION**

Self reset contacts. N/O contacts pick up when the relay is energised & drop out when the operate voltage is removed.

**OPERATING TIME**

Less than 10ms at nominal rated operating voltage.

**FLAG OPERATION**

Drops on coil energisation.  
Hand reset when the contacts are in the reset position.

**OPERATING VOLTAGE RANGE**

Guaranteed operation between 65% & 120% of nominal rated operating voltage.

Note: The 65% of nominal value allows for correct operation of the tripping systems even when there is a loss of battery charger supply for considerable periods.

To ensure guaranteed operation at 65% of nominal voltage the relay is manufactured to operate at a lower level to guarantee operation if the voltage falls to 65% of nominal voltage. Consequently, it will be found that these relays will operate below 65% of nominal voltage, this is normal and correct.

The 65% of nominal voltage figure does not indicate the relay pickup voltage.

**RESET VOLTAGE**

Self reset relays will reset at not less than 5% of nominal rated operate voltage.

**AC VOLTAGES**

Standard 6RJ relays are not intended for operation with AC voltages. Application of continuous AC voltage below the pick up level will cause excessive power dissipation in the capacitor discharge resistor & likely result in thermal damage to the device.

**NOMINAL OPERATING VOLTAGES**

24, 32, 48, 110, 125, 220, 240 & 250V DC available.

**MINIMUM OPERATING CURRENT**

Low burden relays: 50mA

**CONTACTS**

5 or 10 contacts

User to specify combination of make & break contacts

**Ordering Codes**

Generate the required ordering code as follows:  
e.g. 6RJ11-10-D-8M2B

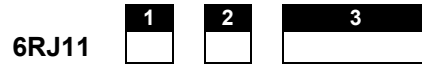

**1 NUMBER OF CONTACTS**

- 5 5 contacts
- 10 10 contacts

**2 NOMINAL OPERATE VOLTAGE**

- |           |           |
|-----------|-----------|
| A 24V DC  | E 125V D  |
| B 32V DC  | G 220V DC |
| C 48V DC  | H 240V DC |
| D 110V DC | F 250V DC |

**3 CONTACT ARRANGEMENT** (Not to exceed maximum)

Specify the number of "MAKES" followed by M; i.e. 8M  
Specify the number of "BREAKS" followed by B; i.e. 2B

**6R RELAY CONTACT RATINGS**

**Make & Carry Continuously**

3,000 VA AC resistive with maximums of 660V & 12A  
3,000 W DC resistive with maximums of 660V & 12A

**Make & Carry for 3 Seconds**

7,500 VA AC resistive with maximums of 660V & 30A  
7,500 W DC resistive with maximums of 660V & 30A

**AC Break Capacity**

3,000 VA AC resistive with maximums of 660V & 12A

**DC Break Capacity (Amps)**

| Voltage                | 24V | 48V | 125V | 250V |
|------------------------|-----|-----|------|------|
| Resistive rating       | 12  | 2   | 0.5  | 0.25 |
| L/R=40ms Maximum break | 12  | 1   | 0.25 | 0.15 |

**INSULATION WITHSTAND** in accordance with IEC 255-5:

2KV RMS & 1.2/50 5KV impulse between:

- ◆ all terminals & frame
- ◆ each contact group
- ◆ all contacts & coil

**CASE SIZE**

2M28-S draw out case

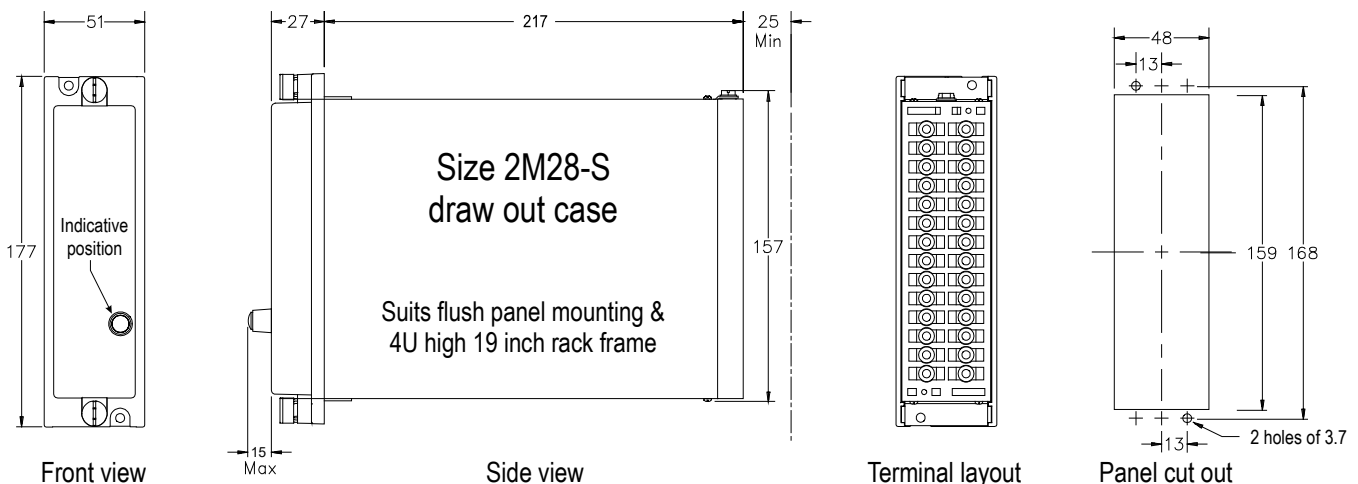

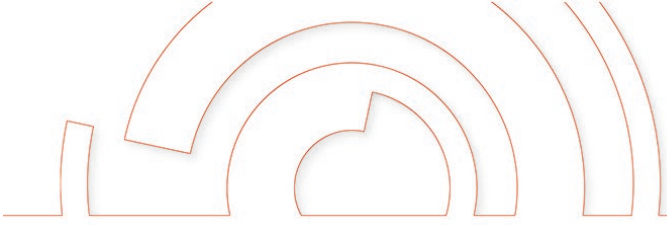

**RMS Mors Smitt**  
A *Wabtec* Company

---

**RMS Mors Smitt**  
19 Southern Court  
Keysborough, VIC 3173, Australia  
Tel: +61 (0)3 8544 1200  
sales.rms@wabtec.com



**RMS Mors Smitt**  
A *Wabtec* Company

**Wabtec Netherlands B.V.**  
Darwinstraat 10  
6718 XR Ede, Netherlands  
Tel: +31 (0)88 600 4500  
wnl\_salessupport@wabtec.com



Visit [www.morssmitt.com/rms](http://www.morssmitt.com/rms) for the latest product information.  
Due to RMS continuous product improvement policy this information is subject to change without notice

