

AUXILIARY | TRIPPING | SUPERVISION | TIMING | ARC FAULT

Delta-Flex

The Delta-Flex System provides a flexible and cost effective method to mount and wire a wide range of auxiliary relays on protection panels.

- > 2U high 19-inch rack or flush mounting
- > Wide range of auxiliary relay functions
- > Specify components or complete sub-rack system
- > M4 screw terminals suitable for ring lugs
- > Integrated front panel covers
- > Custom panel labelling

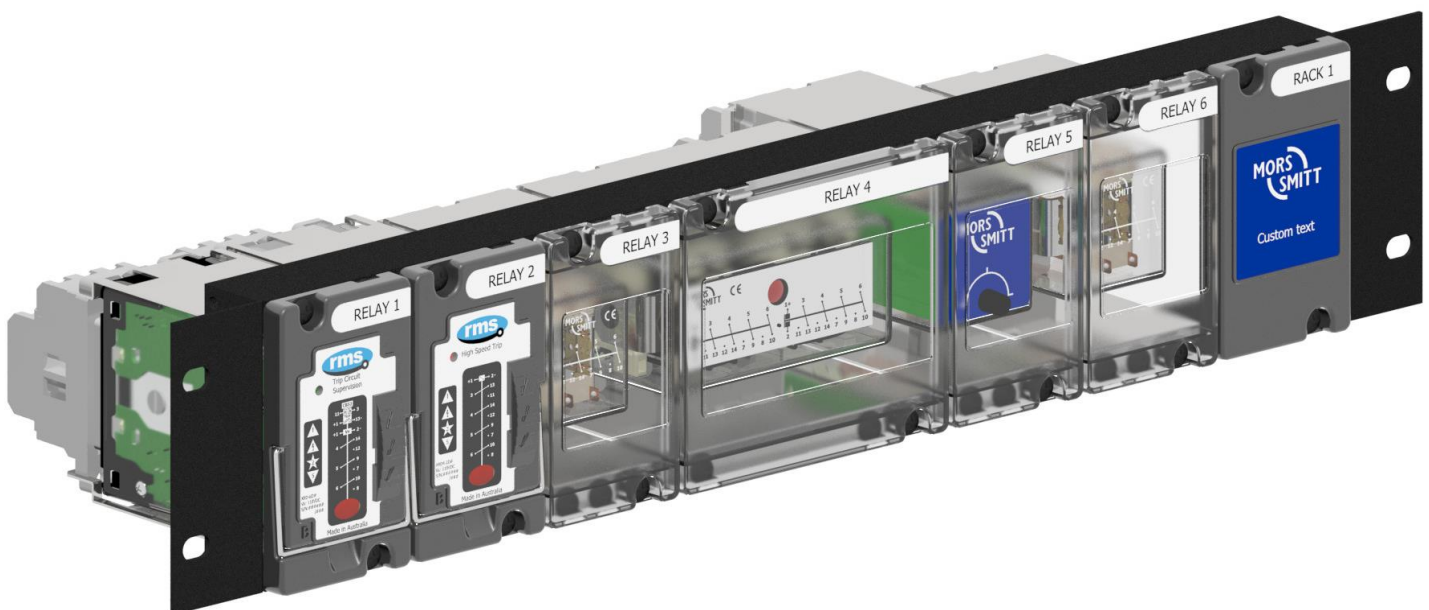

Description

The Delta-Flex System provides a convenient standardized method to design, specify and build high quality auxiliary relay panels for high voltage protection and control applications.

Front Panel

The Delta-Flex system dimensions are based on the European 19-inch rack standard:

- > Height 2 units
- > Width 16 units

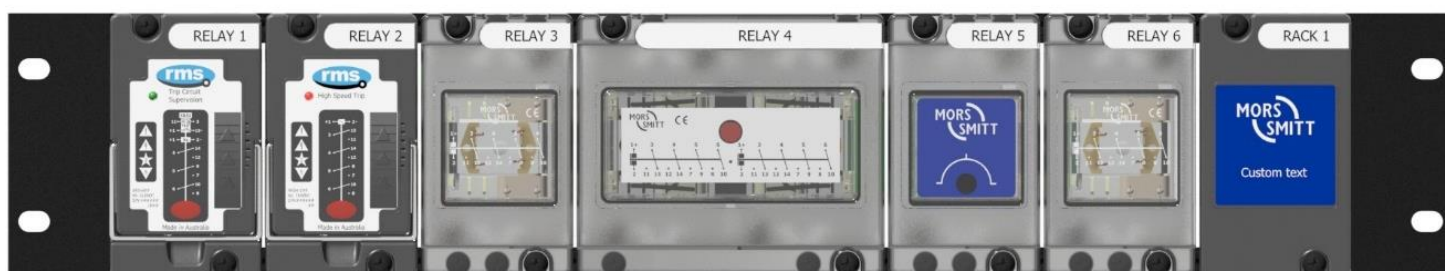

Figure 1: Example of a fully populated Delta-Flex sub-rack

Relay Elements

Relay elements are either 2 or 4 units wide depending on the model functionality. Elements may be mixed on the panel up to a maximum of 16 units wide. Blanking panels 2 units wide are used to fill unused space.

- > Width Size 2 elements 2 unit's wide
 Size 4 elements 4 unit's wide

Rear Terminals

Standard rear terminals are M4 crews suitable for 2x ring lug terminals per connection.

Optional rear terminals such as Faston or cage clamp terminals are also available.

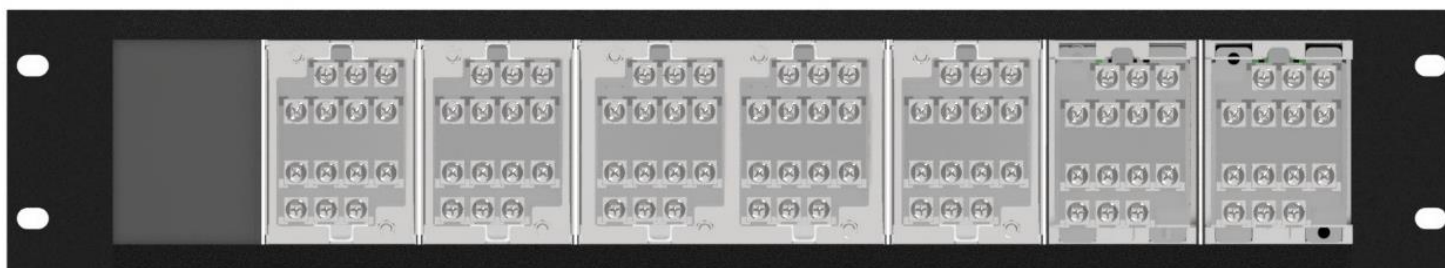

Figure 2: Rear view of the Delta-Flex rack from figure 1 showing the screw terminal (V34) arrangement

Flush Mount Sub-Rack Frame

The sub-rack frame is also available with top and bottom panels fitted to make it suitable for flush mounting.

Size 2 Element Assembly

Figure 3 is an enlarged view of a single size 2 element assembled and mounted between the sub-rack top and bottom rails.

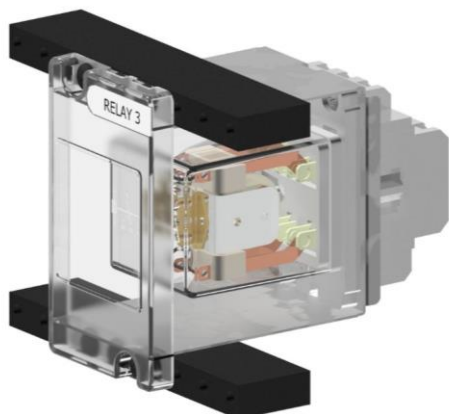

Figure 3: Size 2 element kit shown assembled onto the sub-rack rails

Size 2 Element Mounting Components

Figure 4 is an exploded view of the size 2 components required for assembly onto a sub-rack frame.

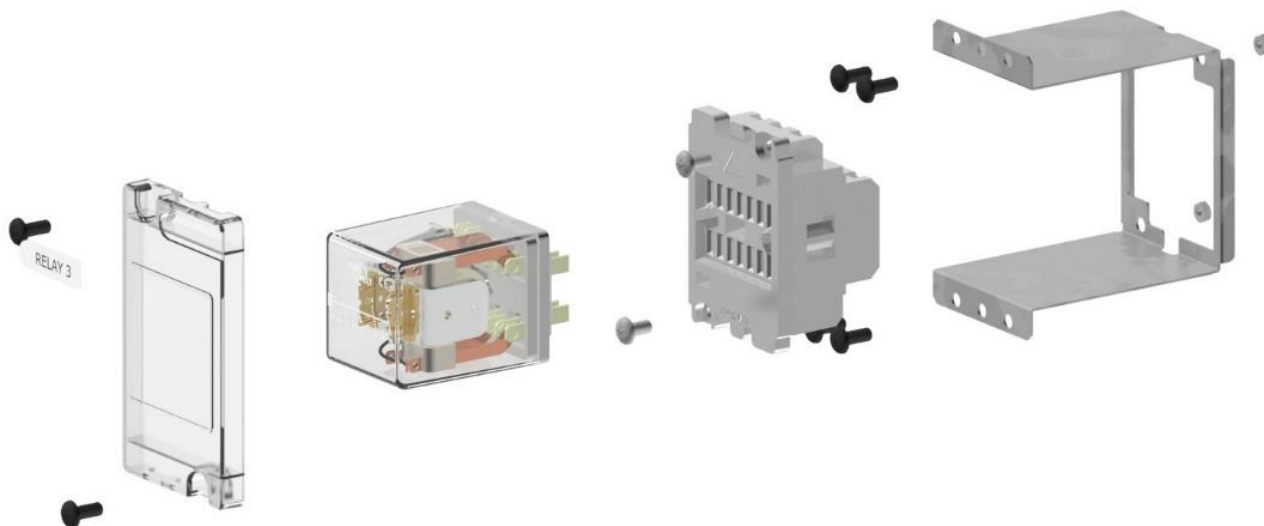

Figure 4: Exploded view of the size 2 element kit

Size 4 Element Assembly

Figure 5 is an enlarged view of a single size 4 element assembled and mounted between the sub-rack top and bottom rails.



Figure 5: Size 4 element kit shown assembled onto the sub-rack rails

Size 4 Element Mounting Components

Figure 6 is an exploded view of the size 4 components required for assembly onto a sub-rack frame.



Figure 6: Exploded view of the size 4 element kit

Relay Elements

Relay Element Selection Chart

The following table lists the relay elements and widths with a cross reference to the DFK mounting kit required for use in the Delta-Flex system.

Refer to the Technical Bulletin for details and order codes to select the specific model for the element type required.

Relay Type	Image	Function	Contacts	Width	Mounting Kit
D DI BD DR		Voltage operated auxiliary relay Current operated auxiliary relay Voltage operated magnetic latch bistable relay Voltage operated high speed relay	4	2	DFK-21
TDB4 TDE4		Time delay on relay Time delay off relay	4	2	DFK-23
UMD ACD		Voltage monitoring relay Battery monitoring relay	2	2	DFK-23
ARD4 TRD4 XRD 1S27		Voltage operated auxiliary relay with mechanical flag Voltage operated high speed relay with mechanical flag Supervision relay Arc flash monitoring relay	4 4 Refer TB Refer TB	2	DFK-24
D8 D8R KDN		Voltage operated auxiliary relay Voltage operated high speed relay Voltage operated mechanical latch bistable relay	8 7 8	4	DFK-41
N/A		Size 2 Blanking plate (Opaque)	N/A	2	DFK-20
N/A		Size 4 Blanking plate (Opaque)	N/A	4	DFK-40

Table 1: Relay element functional table TB – Technical Bulletin N/A – Not applicable

Sub-Rack Frame Order Codes

Two (2) sub-rack frame types are available as per figures 7 and 8:

- > 4M800-2U 19-inch rack mount version
- > 4M800-2U-P Flush panel mount version

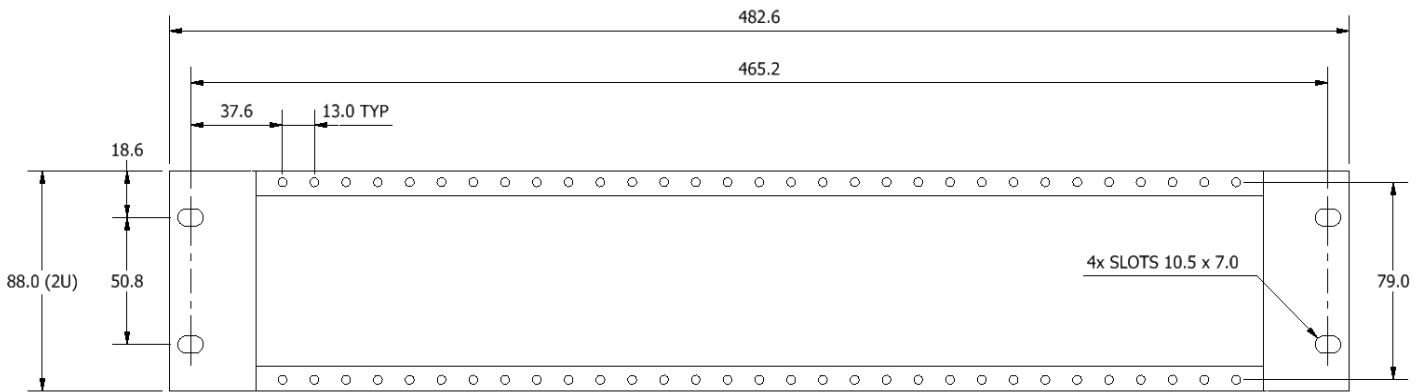

Figure 7: 4M800-2U Sub-rack frame for mounting in a 19-inch rack

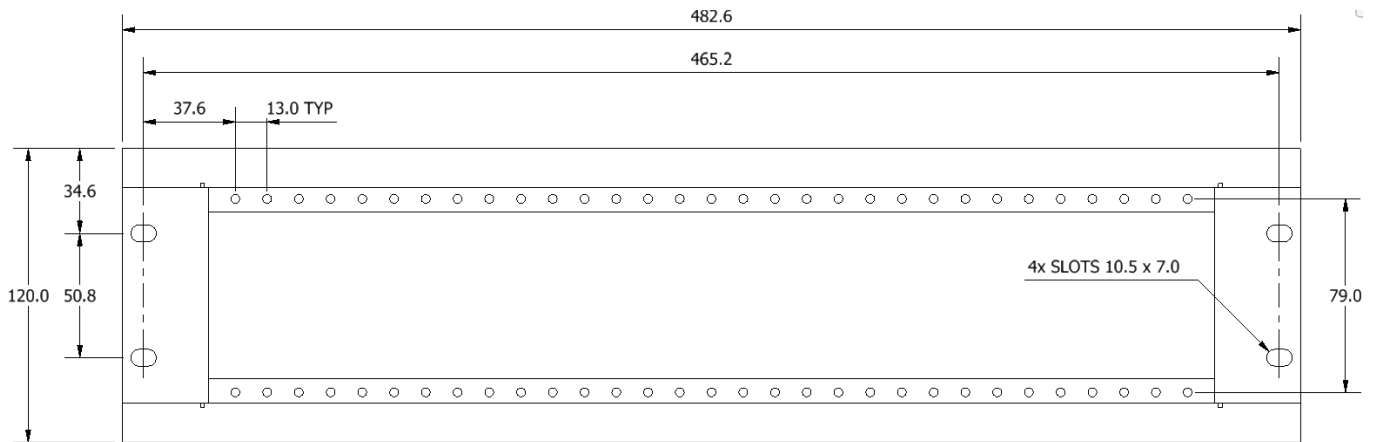

Figure 8: 4M800-2U-P Sub-rack frame for flush mounting

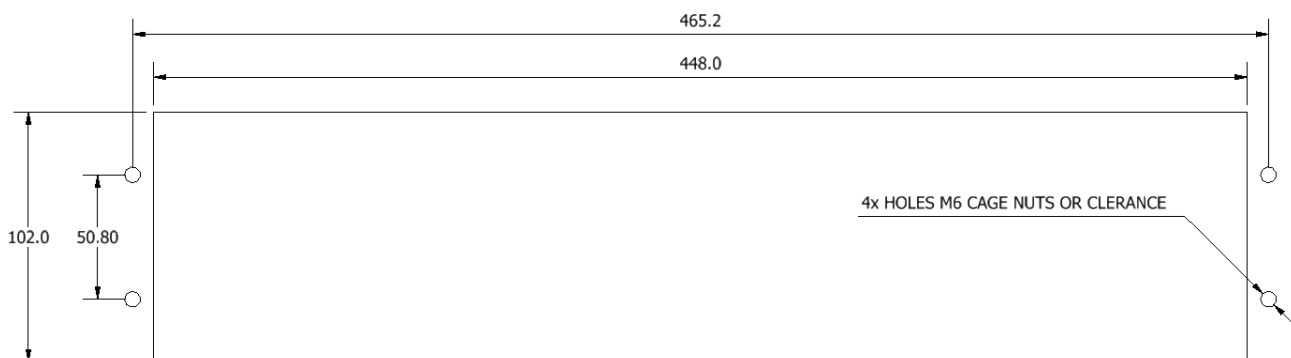
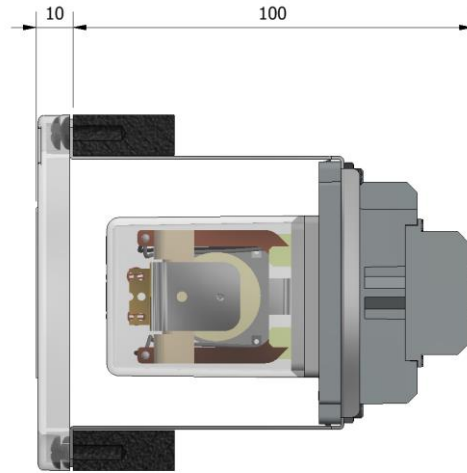

Figure 9: Panel cut-out for flush mounting 4M800-2U-P Sub-rack frame

Relay Element Dimensions

Relay Mounting Kit Depth

Allow an additional 10mm clearance for wiring at the rear.



Module Depth Code 1 – Short

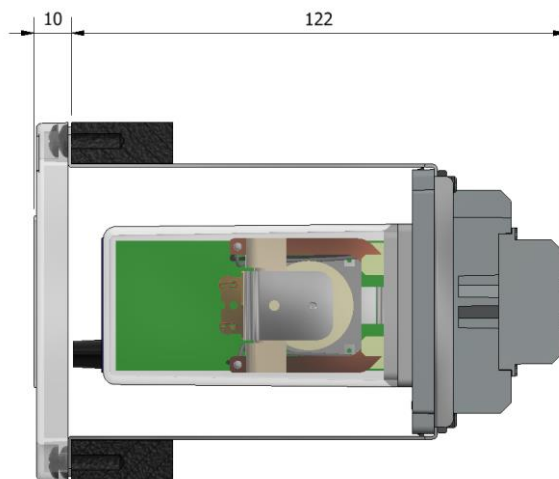

Module Depth Code 3 – Long

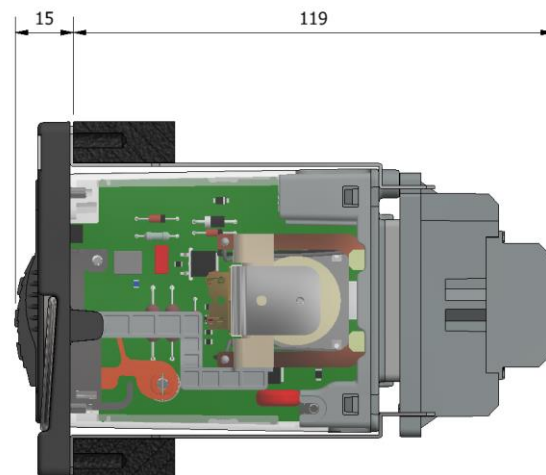

Module Depth Code 4 – Delta relays

Figure 10: Relay element mounting depth dimensions

General

The following standards compliance data is applicable to the Delta-Flex relay mounting system. The specific standards compliance for each relay element is available in from the Technical Bulletin for each device.

Insulation

Standard	IEC 60255-5
Type	Level
Any Terminal and Earth	2.0kV ac rms for 1min
	5.0kV 1.2/50us 0.5J
Between Independent Circuits	2.0kV ac rms for 1min
	5.0kV 1.2/50us 0.5J
Across Normally Open Contacts	1.0kV ac rms for 1min

Temperature

Standard	IEC 60068-2-1/2
Operating Range	-10 to +55 degrees Celsius
Storage Range	-25 to +70 degrees Celsius

Humidity

Standard	IEC 680068-2-78
Operating Range	40 degrees Celsius and 93% RH non condensing

IP Rating

Standard	IEC 60529
Installed	IP5x

Vibration - Sinusoidal

Standard	IEC 60255-21-1 Class I	
Vibration Response	0.5gn	≤5%
Vibration Endurance	1.0gn	≤5%

Shock and Bump

Standard	IEC 60255-21-2 Class I	
Shock Response	5gn, 11ms	≤5%
Shock Withstand	15gn, 11ms	≤5%
Bump Test	10gn, 16ms	≤5%

Seismic

Standard	IEC 60255-21-3 Class I	
Seismic Response	1gn	≤5%

Mechanical Classification

Durability - 0.1 Hz maximum repetition rate	>10 ⁵ operations at no load
	>10 ⁴ operations at full load

Configuration and Ordering

Relays, terminal block mounting kits and sub-rack frames may be selected and ordered separately for assembly by the system integrator.

Alternatively, the system may be specified for delivery as a complete, pre-assembled Delta-Flex sub-rack ready for installation on a panel and final wiring.

The following five (5) step process may be used to create a unique panel design and bill of materials to allow ordering of individual components or as a pre-assembled Delta-Flex sub-rack assembly. An example is shown in table 3.

The Delta-Flex configuration form is available as an Excel spreadsheet to simplify the sub-rack design and specification process. <https://www.morssmitt.com/products/201566/delta-flex?catId=201480>

Mounting Kit Order Codes

Table 2 describes the mounting kit order code.

The module width and module depth may be selected from table 1.

The connection termination type suffix must be added from table 2 to complete the mounting kit order code.

Step One

Select the relay elements required to meet the panel functional requirements from table 1. The order code for each relay is determined by referring to the Technical Bulletins for the specific model.

Step Two

Select the mounting kit required for each relay element from table 1. Now add the desired connection termination suffix from table 2.

Step Three

Select the start and end position for each relay element. Fill empty spaces with size 2 or size 4 blanking panels and specify where custom text is required.

The end position cannot exceed position 16.

Step Four

Specify custom text on each front panel
Specify additional text on blanking panels

Step Five

Specify the sub-rack frame: Rack or flush mount
Specify the type of supply: Components or Assembled

DFK -	[]	[]	[]	[]	Delta-Flex Relay Mounting Kit
Module Width	2				Size 2 - Two unit's wide
	4				Size 4 - Four unit's wide
Module Type		0			Cover only
		1			Short relay
		3			Long relay
		4			Delta relay
Connection Termination			0		Cover only
			1		Rear connect Faston spade terminals
			2		Rear connect cage clamps
			3		Rear connect M4 screw terminals
Options				-	
				T	Custom text – specify separately

Table 2: Mounting kit order code definition

Delta-Flex Sub-Rack Configuration

Table 3 is an example of a Delta-Flex configuration table for the relay rack depicted in figure 11.

This table may be used as a bill of materials to order components or a factory assemble Delta-Flex sub-rack.

If an assembled sub-rack is specified a unique part code will be allocated by the factory in the form: DFLX-0000

Custom Text

If custom text is specified at Step 4, this information should be supplied in the space provided on the Delta-Flex configuration form available as an Excel spreadsheet on the Mors Smitt web site. <https://www.morssmitt.com/products/201566/delta-flex?catId=201480>

Position Codes		01	02	03	04	05	06	07	08	09	10	11	12	13	14	15	16
Step 1	Relay Code Refer Table 1	TRD4		TRD4		D		KDN		-		TDB4		BD		-	
	Relay Order Code Detail Refer Technical Bulletins	-1DB		-4DB		---D110		--D110		-		-110-06S		--D110		-	
Step 2	Mounting Kit Refer Table 1	DFK-24		DFK-24		DFK-21		DFK-41		-		DFK-23		DFK-21		DFK-200	
	Terminal Suffix Refer Table 2	3		3		3		3		-		3		3		0	
Step 3	Position Code Start	01		03		05		07		-		11		13		15	
	Position Code Finish	02		04		06		10		10		12		14		16	
Step 4	Custom Text - TOP	RELAY 1		RELAY 2		RELAY 3		RELAY 4				RELAY 5		RELAY 6		RACK 1	
	Custom Text – FRONT DFK-200 / DFK-400 only																Mors Smitt
Step 5	Sub-rack Mounting Frame Refer figures 7 and 8	4M800-2U - Assembled															

Table 3

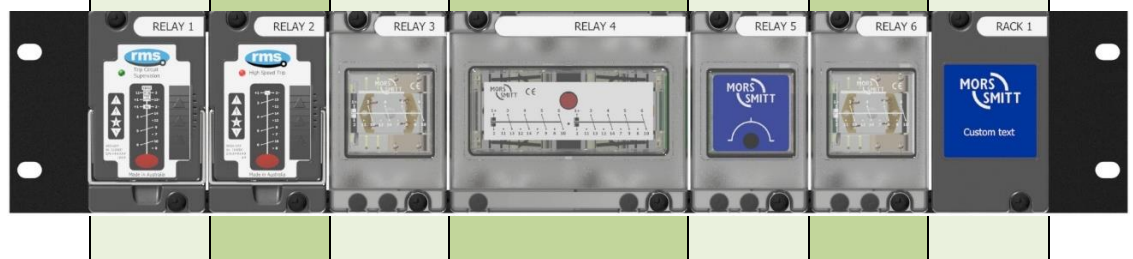

Figure 11: Delta-Flex Sub-Rack Example

The factory allocated code for this example is: DFLX-0001

System Configuration

	Position Codes	01	02	03	04	05	06	07	08	09	10	11	12	13	14	15	16
Step 1	Relay Code Refer Table 1																
	Relay Order Code Detail Refer Technical Bulletins																
Step 2	Mounting Kit Refer Table 1																
	Terminal Suffix Refer Table 2																
Step 3	Position Code Start																
	Position Code Finish																
Step 4	Custom Text - TOP																
	Custom Text - FRONT DFK-200 / DFK-400 only																
Step 5	Sub-rack Mounting Frame Refer figures 7 and 8																

The factory allocated code for this example is: DFLX- _ _ _ _ _

RMS Mors Smitt
19 Southern Court
Keysborough, VIC 3173, Australia
Tel: +61 (0)3 8544 1200
sales.rms@wabtec.com



Wabtec Netherlands B.V.
Darwinstraat 10
6718 XR Ede, Netherlands
Tel: +31 (0)88 600 4500
sales.msbv@wabtec.com



Visit www.morssmitt.com/rms for the latest product information.
Due to RMS continuous product improvement policy this information is subject to change without notice