

User manual

Earth Resistance Tester

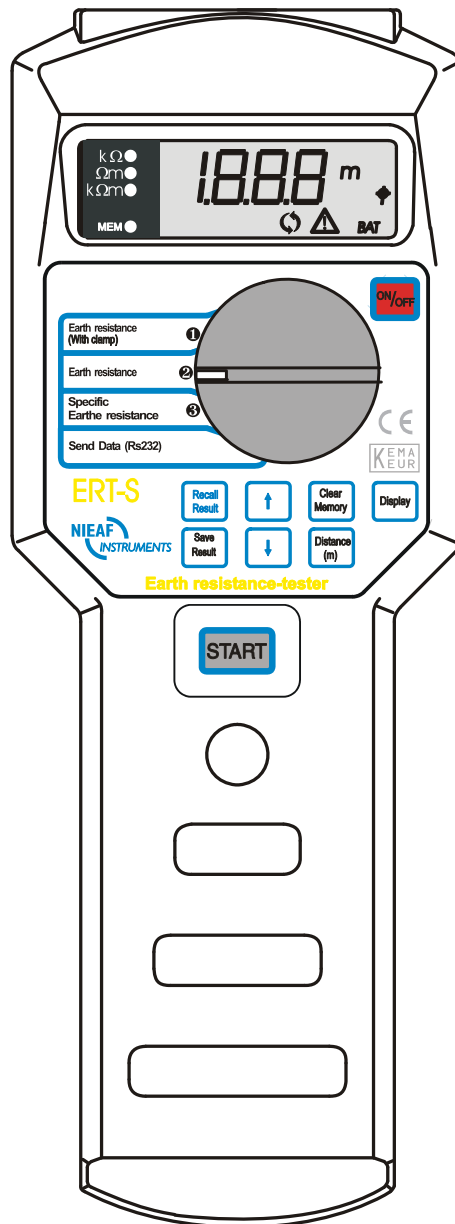

Supplier:	Nieaf-Smitt bv Vrieslantlaan 6 3526 AA Utrecht Holland P.O. box 7023 3502 KA Utrecht
Specifications of the equipment:	ERT-S
Specifications of the user manual:	Date: 05-02-2004 Number: 561144039 Ref.: 004

Preface

This manual describes the Earth Resistance Tester. The information in this manual is important for proper and safe functioning of the machine. In case you are not familiar with the operation, the preventive maintenance, etc. of the Earth Resistance Tester, then you read this user manual from the beginning to the end thoroughly.

If you are familiar with these matters, you can use this manual for reference. You can find the required information rapidly using the table of contents.

In this user manual, the following four marking conventions are used to focus attention on certain subjects or actions.

	<p style="text-align: center;">TIP: <i>gives you suggestions and advice to perform certain tasks easier or handier.</i></p>
---	--

	<p style="text-align: center;">ATTENTION: <i>a remark with additional information; draws your attention to possible problems.</i></p>
---	--

	<p style="text-align: center;">CAUTION: <i>the machine may be damaged, if you do not carefully execute the procedures.</i></p>
---	---

	<p style="text-align: center;">WARNING FOR DANGER: <i>you can (seriously) hurt yourself or seriously damage the product, if you do not carefully execute the procedures.</i></p>
---	---

- this document is described with the words manual or user manual;
- the test equipment is described with the words tester, instrument or test device;
- values or displayed data is placed between inverted commas for example “230 V”;
- keys or switch positions are placed between angular brackets for example [START] key.

Warranty

Nieaf-Smitt bv guarantees the tester for a period of 6 months.

The period of warranty will be effective at the day of delivery. The warranty clauses and the stipulations regarding liability in terms of delivery (FME and HE).

© Copyright 1997-2002

All rights reserved. Nothing from this edition may be multiplied, or made public in any form or manner, either electronically, mechanically, by photocopying, recording, or in any manner, without prior written consent from Nieaf-Smitt bv.





Nieaf-Smitt bv reserves the right to change parts at any given moment, without prior or direct notification to the client. The contents of this user manual may also be changed without prior warning.

This user manual is compiled with all possible care, but Nieaf-Smitt bv can not accept any responsibility for possible errors in this user manual or any consequences resulting from that.

Warning pictograms on the tester

There are a number of pictograms on the tester, meant to warn the user of remaining risks that may be present in spite of the safe design.

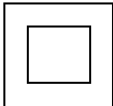
Table 1: Pictograms on the tester

Pictogram	Description	Location on the tester
	Warning: General sign for danger. Read the instructions carefully before use.	At the back side of the tester on the instruction label and on the left side of the tester.
	Warning: Danger for direct contact with live parts.	At the back side of the tester on the instruction label and under the battery cover.
	Mark: Insulation class II (double insulation).	At the back side of the tester on the instruction label.
	Mark: Marks the KEMA certification of the tester.	The KEMA KEUR is placed on the front side of the tester.
	CE-mark: Declares the conformity with the European Directives.	The CE-mark is placed on the front side of the tester.

All peripherals, which are used by this tester, must be provided with a CE-mark. For example the use of a PC.

CONTENTS

<u>1.</u>	<u>GENERAL SAFETY REGULATIONS</u>	7
<u>2.</u>	<u>INTRODUCTION</u>	8
2.1	GENERAL	8
2.1.1	<u>The intended use</u>	8
2.1.2	<u>Target group</u>	8
2.1.3	<u>Working principle</u>	9
2.2	SPECIFICATIONS	10
2.3	CERTIFICATION	13
<u>3.</u>	<u>TESTER COMPOSITION</u>	14
3.1	GENERAL	14
3.2	PRINCIPLE OF MEASUREMENT	15
3.2.1	<u>Visual inspection</u>	15
3.2.2	<u>Two point earth resistance measurement</u>	15
3.2.3	<u>Three point earth resistance measurement</u>	15
3.2.4	<u>Clamp system earth resistance measurement</u>	15
3.2.5	<u>Soil resistivity test: ('Wenner'-method)</u>	15
<u>4.</u>	<u>INSTALLATION; START-UP AND ADJUSTING</u>	16
<u>5.</u>	<u>HOW TO USE THE TESTER?</u>	17
5.1	OPERATION	17
5.1.1	<u>Starting</u>	18
5.2	TESTING	19
5.2.1	<u>Test 1: Two point earth resistance measurement</u>	19
5.2.2	<u>Test 2: Three point earth resistance measurement</u>	20
5.2.3	<u>Test 3: Partial earth resistance (UTILITY-method)</u>	20
5.2.4	<u>Test 4: Soil resistivity test ('Wenner'-method)</u>	21
5.3	MEMORISING OF RESULTS	23
5.4	RECALLING OF MEMORISED RESULTS	24
5.5	RS232 COMMUNICATION	26
5.6	ERASING OF RESULTS	28
5.7	RESET OF THE INSTRUMENT	30
5.8	TROUBLESHOOTING	30
5.9	CALIBRATION AND REPAIR	31
<u>6.</u>	<u>MAINTENANCE</u>	32
6.1	BATTERIES REPLACEMENT	32
6.2	CLEANING	33
<u>7.</u>	<u>ACCESSORY AND REPLACEABLE PARTS</u>	34

Tables:

Table 1: Pictograms on the tester

Table 2: Switches

Table 3: Save results in the memory

Table 4: General faults and display messages

Figures:

Figure 1: Three point earth resistance measurement

Figure 2: Clamp system earth resistance measurement

Figure 3: Soil resistivity measurement

Figure 4: Operating

Figure 5: Identification number of each function

Figure 6: RS232 connector

Figure 7: RS232 cable

Figure 8: An example of print out

Figure 9: Batteries inserted

Figure 10: Test cords







Attachments:

Attachment 1: EU-Declaration of Conformity

Attachment 2: Circuit diagrams

- Two-point earth resistance measurement*
- Three-point earth resistance measurement*
- Clamp system earth resistance measurement*
- Four-point specific earth resistance measurement*

1. GENERAL SAFETY REGULATIONS

	<p><i>Read, before you perform any action in connection with the tester, this user manual carefully.</i></p> <p><i>Nieaf-Smitt bv is not liable for injuries, (financial) damage and/or excessive wear resulting from incorrectly performed maintenance, incorrect use of or modifications to the instrument.</i></p>
	<p><i>It is not allowed to remove, to skirt or to tide over (by handy constructions) the enclosure or safeties of the tester during normal use.</i></p> <p><i>Method of measurement and range are indicated on the back side of the instrument.</i></p>
	<p><i>It's forbidden to place and/or use the instrument in a room where is a risk of explosion.</i></p>
	<p><i>If the tester is used by a third party, you being the owner are responsible, unless otherwise specified.</i></p>
	<p><i>Repair can only be done by Nieaf-Smitt bv.</i></p>
	<p><i>Provide a clean and save workplace which has sufficient lightning.</i></p>

2. INTRODUCTION

2.1 GENERAL

2.1.1 The intended use

The resistance tester is intended to be used for judgement of the safety of electrical installations.

The portable tester is intended for two or three-point earth resistance measurements, as well as specific earth resistance measurement. If the instrument is used in manner not specified in this user manual, the protection provided by the instrument may be impaired and the supplier is excluded from any responsibility.

2.1.2 Target group

The target group of people for whom the tester and this user manual are applicable are competent and technical qualified persons.

Competent persons are persons who:

- have got a certain level of technical knowledge gained by education/training and who;
- have got certain skills required to operate the tester.

Technical qualified persons are persons who:

- are competent and who;
- have got a certain level of technical knowledge gained by education/training and who;
- are familiar with the applied technology in the instrument and are aware of the possible dangers and risks.



Repair can only be done by Nieaf-Smitt bv.

By operating we mean:

- setting up the instrument and executing tests;
- processing the test results.

2.1.3 Working principle

Structure

The ERT-S is a electronic instrument intended for execution resistance and/or specific earth resistance measurements. Select the test by means of the rotary switch. Now the user is able to prescribe the desired measuring method. The test results are clearly displayed on the LCD.

Connecting

The instrument is powered by four alkaline batteries (4 x 1,5 V IEC). The tester is provided with a on/off switch and can, after powering up the instrument, be used at once. The test cord or the RS232 cable (data transfer cable) are connected at the upper side of the tester.

Measuring

Each test has it's specific circuit diagram which is given in the attachments.
Next measurements are executable by the instrument:

1. A two-point earth resistance measurement
2. A three-point earth resistance measurement
3. A clamp system earth resistance measurement
4. A four-point specific earth resistance measurement

2.2 SPECIFICATIONS

General

Power supply	:	4 x 1,5 V IEC LR14 alkaline batteries
Battery life time	:	approx. 2000 measurements (1 measurement per 5 minutes)
Display	:	3 digit 7 segment LCD 19 mm with additional warnings
Quality standard	:	design, development and production according to ISO 9001
Mass	:	approx. 0,75 kg including batteries and accessories
Dimensions (wxhxd)	:	110 x 65 x 290 mm

Environment and storage

Reference temp. range	:	5°C - 35°C
Operating temp. range	:	0°C - 40°C
Storage temp. range	:	-10°C - 60°C
Max. operating humidity	:	85% RH (0°C - 40°C)
Max. storage humidity	:	80% RH (40°C - 60°C) 90% RH (-10°C - 40°C)
Degree of protection	:	IP50
Pollution degree	:	Class II
Overvoltage protection	:	Category II 300V

Tested

Three point earth resistance measurement

Range (Σ)*	Resolution (Σ)	Accuracy
0 - 19,99	0,01	\pm (2% + 2 digits)
20,0 - 199,9	0,1	\pm (2% + 2 digits)
200 - 999	1	\pm (2% + 2 digits)
1,00k - 9,99k	10	\pm 5%
10,0k - 50,0k	100	\pm 5%

* Automatic range selection

Measuring frequency	:	125 Hz \pm 1 Hz For special frequency see backlabel
Measuring voltage (sinwave)	:	< 50 V _{EFF}
Measuring current	:	< 20 mA _{EFF}
Interference	:	Interference voltage 5V _{pp} / 50Hz at the potential input will have max. effect of \pm 15 dig.

Allowed current spike resistance (R_{cmax}) :

Allowed current spike resistance R_{cmax} that will introduce an additional up to 3% (of reading) error is as follows:

$$R_{cmax} = (4k\Sigma + 100R_E) \text{ or}$$

$$R_{cmax} = 50k\Sigma, \text{ whichever is lower.}$$

Allowed potential spike resistance (R_{pmax}) :
 Allowed potential spike resistance R_{pmax} that will introduce an additional up to 3% (of reading) error is as follows:
 $R_{pmax} = (4k\Sigma + 100R_E)$ or
 $R_{pmax} = 50k\Sigma$, whichever is lower.

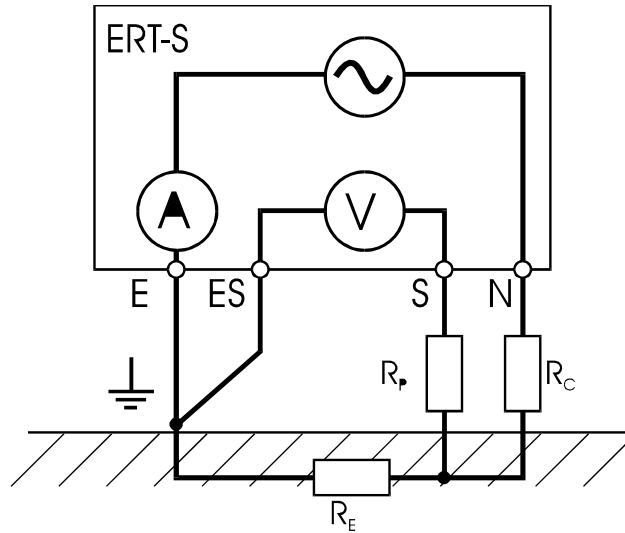

Figure 1. Three point earth resistance measurement

Clamp system earth resistance measurement

Range (Σ)*	Resolution (Σ)	Accuracy **
0,5 - 19,9	0,1	$\pm (5\% + 2 \text{ digits})$
20 - 999	1	$\pm (5\% + 2 \text{ digits})$
1,00k - 2,00k	10	$\pm (5\% + 2 \text{ digits})$

* Automatic range selector

** Clamp's inaccuracy must be additionally respected

Measuring frequency : 125 Hz \pm 1 Hz (See backlabel for special frequency)
 Measuring voltage (sinwave) : $< 50 V_{EFF}$
 Measuring current : $< 20 mA_{EFF}$
 Interference : Interference voltage 5Vpp / 50Hz at the potential input will have max. effect of ± 15 digits.

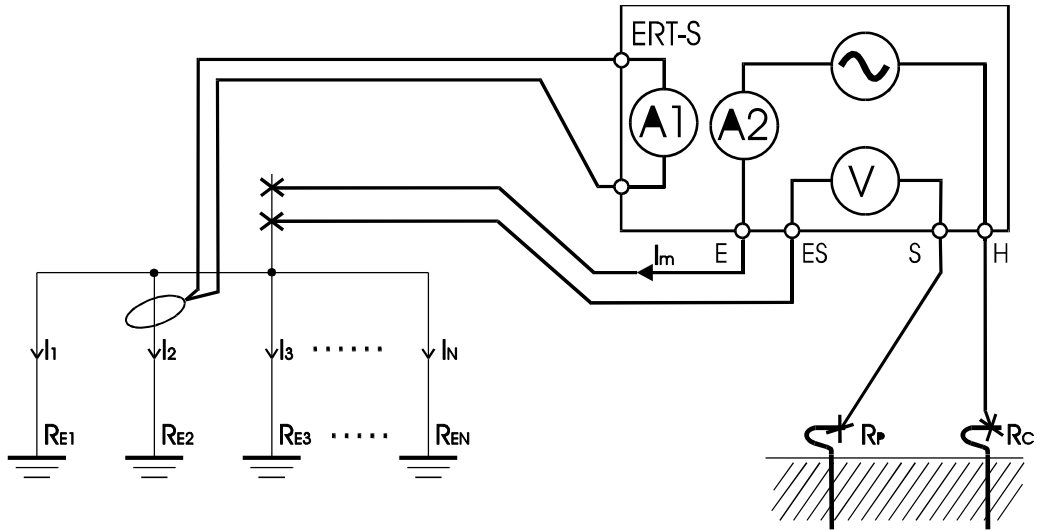

Figure 2. Clamp system earth resistance measurement

$$I_1 + I_2 + I_3 + \dots + I_N = I_m$$

$$R_{E2} = \frac{U}{I_2(A1)} \quad ; \quad R_{TOT} = R_1 \parallel R_2 \parallel R_3 \dots \parallel R_N = \frac{U}{I_m(A2)}$$

Measurement of specific earth resistance

Range Δ (Σm) *	Resolution (Σm)	Accuracy $\Delta = 2aR$
0 - 19,99	0,01	$\pm (2\% + 2\Delta \cdot 0,02 \Sigma)$; $R \# 19,99 \Sigma$
20,0 - 199,9	0,1	$\pm (2\% + 2\Delta \cdot 0,2 \Sigma)$; $19,99 \Sigma < R \# 199,9 \Sigma$
200 - 999	1	$\pm (2\% + 2\Delta \cdot 2 \Sigma)$; $199,9 \Sigma < R \# 999 \Sigma$
1,00k - 9,99k	10	$\pm 5\%$; $999k \Sigma < R \# 9,99k \Sigma$
10,0k - 99,9k	100	$\pm 5\%$; $9,99k \Sigma < R \# 50,0k \Sigma$
100k - 1999k	1000	

* Automatic range selection

Possible adjustment of the distance between two measuring rods : 1 up to 20m in steps of 1m.

See all the rest technical specifications in paragraph “ Three point earth resistance measurement”.

Take into account : $R_C = R_{C1} + R_{C2}$ en $R_P = R_{P1} + R_{P2}$, see figure 3.

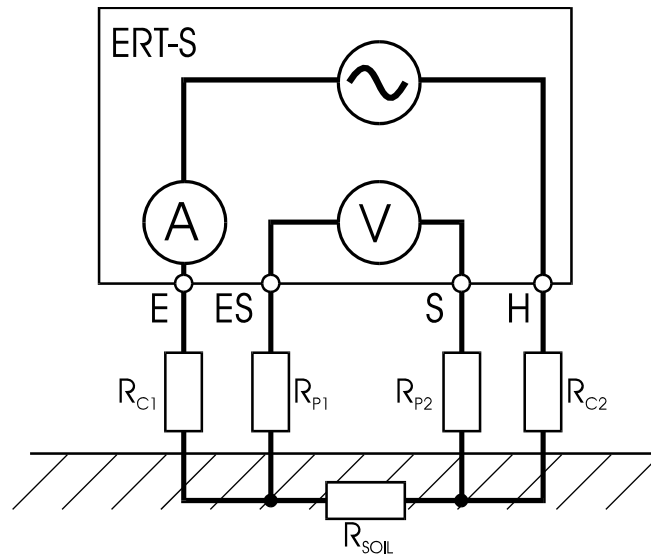

Figure 3: Soil resistivity measurement

Transport

The tester is a portable test device which can be hand-held or lay down (solid foundation) during the tests. Take care of the instrument during transport to avoid any damage.

2.3 CERTIFICATION

The tester and this manual have been designed, constructed and tested according to the European directives. During all these phases the relevant (preliminary European standards have been taken into account. The CE-mark has been mounted on the instrument. The directives and the standards mentioned are enumerated in the EC-Declaration of Conformity.

3. TESTER COMPOSITION

3.1 GENERAL

The ERT-S is built in an enclosure of solid ABS plastic. The display is situated at the front side of the tester. The test results are displayed. The main parts (see figures in Chapter 5) are listed below:

Front:

1. On/off key
2. Rotary switch
3. LCD-display (NR. 13 in the figure)

Back:

1. Instruction label
2. Serial number
3. Battery cover
4. Battery cover fastening screw

3.2 PRINCIPLE OF MEASUREMENT

3.2.1 Visual inspection

Visually check the test object or installation before executing the safety tests. The function of the visual inspection is to ensure the electrical safety of the latter parts. Check wires, cables and components for possible damages. If any damage has been noticed, it isn't allowed to perform any tests before a technical qualified person has repaired the test object or installation. The visual inspection is executed by the operator.

3.2.2 Two point earth resistance measurement

Earth resistance measurement by means of a well earth (and available) terminal.

3.2.3 Three point earth resistance measurement

Earth resistance measurement by means of two test clamps.

3.2.4 Clamp system earth resistance measurement

If there are more than one earth systems connected parallel, then it is very important to know what's the quality of each system separately. In order to test each system separately, without using a clamp, each system should be separated mechanically; mechanical connections are usually critical to be disconnected because of rusty connection components, like screws, nuts, spacers etc.. Therefore it's advisable to use the clamp system for testing of such earth appliances without disconnecting them.

3.2.5 Soil resistivity test: ('Wenner'-method)

The 'Wenner'-method is the industry standard. In 1915, Dr. F. Wenner of U.S. the Bureau of standards developed the "Four electrode method" to determine resistivity. The four test rods are driven at equal distances "a", at a depth of 5% of "a". The resistance will be measured, and a calculation will be executed.

The soil resistivity, is measured in ohm meters and symbolised by Δ (Rho) and is calculated by the following formula:

$$\Delta = 2BaR$$

Where:

a = Distance between the rods.

R = Resistance of the soil between ES and E terminals.

4. INSTALLATION; START-UP AND ADJUSTING



The tester can only be used if no damages or defects are noticed and all original components belonging to the tester are mounted



The transportation and the handling of the tester should be done carefully to prevent any damage.

This paragraph describes the installation and the starting up procedure of the instrument. The installation, the starting up and the adjustment of the instrument may be done by competent persons.

1. Unpack the instrument.
Remove the packing materials without causing damages to the environment. Check the tester on possible damages. If damages are noticed, contact Nieaf-Smitt bv..
2. Put the instrument in a horizontal position, at the workplace or on a table in the test room.
Keep enough clearance around the instrument to facilitate an easy operation, adjustment and reading of test results, without any problems or extra danger.
3. Insert the batteries in the instrument.
4. Connect the test object according to the circuit diagrams with the ERT-S.
5. Carry out the selected test.



Find a place to put the manual such that it is within reach during the use of the instrument.

5. HOW TO USE THE TESTER?

5.1 OPERATION

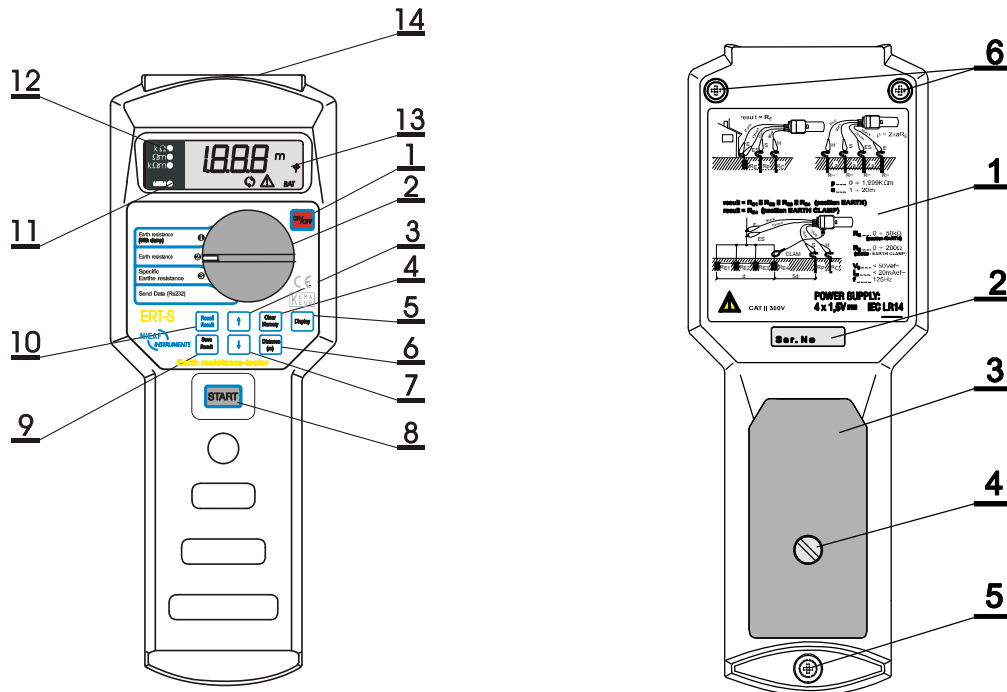

1. On/off key
2. Rotary switch
3. Increase key of memory location
4. Erase key of memory location
5. DISPLAY key
6. Distance test clamp (m) key
7. Decrease key of memory location
8. START key
9. Store key to save measuring results
10. Recall key to recall saved results
11. Memory indication LED
12. Nominal voltage LED
13. LCD Display
14. Connection (functional and RS232)

1. Instruction label
2. Serial number
3. Battery cover
4. fixing screw for battery cover
5. Plastic cover of the locking screw
6. Locking screw covered by a rubber foot

Figure 4: Operating

Keys

Function key description.

Table 2: Switches

Selector position	Description
ON/OFF	- to switch on/off the tester; the tester will switch off automatically after it hasn't been used for ten minutes or more;
Recall result	- to recall the saved results;
Save result	- to save the displayed measuring results;
↑	- to increase/decrease the object or measuring place identification number when saving or recalling the results;
↓	- to check, in the [Recall Result] function, other results which have been saved later than the displayed one under the same object and measuring place identification number;
Clear memory	- to clear all saved results; - to clear all saved results under a certain object identification number (without dots YYY); - to clear the saved results under a certain measuring place identification number only (with dots XXX); - to clear, in the [Recall Result]-function, the displayed result only; - to execute a RESET of the instrument.
Distance (m)	- to set the distance between the two rods (1 up to 20 m) when measuring the earth resistance;
Display	- to select, in the [Save Result] or in the [Recall Result]-function, the object identification number or measuring place identification number
Earth resistance	- to measure the three and two point earth resistance and to measure the total earth resistance at a soil earth resistivity measurement;
Earth resistance (with clamp)	- to set the partial earth at a resistance soil earth resistivity measurement with clamp system;
Specific earth resistance	- position for specific earth resistance measurement;
Send Data (RS232)	- transfer stored data to the printer or to the PC.

5.1.1 Starting

	<p><i>Operating the instrument may only be done by competent persons. Never open the instrument during the testing.</i></p> <p><i>Check before every test:</i></p> <ul style="list-style-type: none"> * cables and test cords on possible damages; * tester on possible damages and/or defects.
---	---

1. Check the instrument on visible damages and/or defects, for example the power plug, the line cord etc.. Don't carry out any test with a damaged or broken instrument. Provide skilled reparation first.
2. Do not connect the test object as well as the test cords with the tester.
3. The instrument can be used at once.

Test selection

First carry out a visual inspection on the test object or the installation. Connect the tester conform the circuit diagrams of attachment 2.

We have four different tests:

Test 1: Two point earth resistance measurement.

Test 2: Three point earth resistance measurement.

Test 3: Partial clamp system earth resistance measurement (UTILITY method).

Test 4: Soil resistivity measurement ('Wenner'-method).

5.2 TESTING



- Avoid testing objects or installations under the influence of high electromagnetic and/or electrostatic fields.

In the following paragraph the test methods will be explained. We consider that the starting-up is carried out as described in paragraph 5.1.1.

5.2.1 Test 1: Two point earth resistance measurement



- If the present voltage difference between E and H is higher than approx. 20 V, will, before pressing the [START] key, the general warning mark appear.*
- During the measurement, higher voltage than 30 V could be present between the test cords and the earth rods;*
- Each result can be saved only once.*

How to carry out test 1:

1. Connect the test cords with the instrument conform the circuit diagram of attachment 2.
2. Set the rotary switch to [Earth resistance].
3. Press the [Start] key and release it.
4. The result is displayed. Read out the result, save it if required, and note the memory codes when necessary.
5. Disconnect the test object or carry out another measurement.

5.2.2 Test 2: Three point earth resistance measurement

	<p>- Both, current and potential spike resistance's will automatically be tested during the measurement. If there is a current spike resistance too high, $[>(4k\Omega+100R_E) \text{ or } >50k\Omega]$, then $r \square$ and the result will flash at the display after finishing the measurement.</p> <p>$r P$ and the result will flash if the potential spike resistance is too high. Find a better place to drive the earth rod and/or pour some salty water around the critical earth rod in order to reduce the resistance.</p> <p>- If the present voltage difference between E and H is higher than approx. 20 V, will, before pressing the [START] key, the general warning mark appear.</p> <p>- Each result can be saved only once..</p>
---	---

How to carry out test 2:

1. Connect the test cords with the instrument conform the circuit diagram of attachment 2.
2. Set the rotary switch to [Earth resistance].
3. Press the [Start] key and release it.
4. The result is displayed. Read out the result, save it if required, and note the memory codes when necessary.
5. Disconnect the test object or carry out another measurement.

5.2.3 Test 3: Partial earth resistance (UTILITY-method)**How to carry out test 3:**

1. Connect the test cords with the instrument conform the circuit diagram of attachment 2.
2. Set the rotary switch to [Earth resistance (with clamp)].
3. Press the [Start] key and release it.
4. The result is displayed. Read out the result, save it if required, and note the memory codes when necessary.
5. Disconnect the test object or carry out another measurement.

The ERT-S takes the clamp information into account therefore the result must be calculated as follows:

$$\text{Result} = \frac{U}{I_{\text{clamp}}} = R_{E2}$$



- Use the original clamp 1000:1, which is not a part of a standard set, can be supplied by NIEAF SMITT upon separate request, in order to reach the technical specification listed in paragraph 2.2;
- The minimal voltage drop (caused by the measuring current) across the R_{TOT} is 0.01V, therefor is the minimal value of R_{TOT} 0.5Ω;
- The minimal current measured by the clamp 1000:1 is 0.5mA;
- If the current, measured by the clamp, is lower than 0.5 mA, the result will flash at the display
- Each result can be saved only once.

5.2.4 Test 4: Soil resistivity test ('Wenner'-method)



- Remember to select the correct distances when executing additional tests at different distances;
- The correct selection of distances must be done before each test otherwise each calculation(s) will be invalid
- Each result can be saved only once.

How to carry out test 4:

1. Connect the test cords with the instrument conform the circuit diagram of attachment 2.
2. Drive the four test rods, equally spaced (=a, 1 # a # 8 m) from each other, into the ground. The depth of the rods is 5% of distance a.
3. Set the rotary switch to [Specific earth resistance].
4. Select the distance between the rods by pressing the [Distance (m)] and the [↑, ↓] keys to save required distance (a), in meters accurate.
5. Press the [Start] key and release it.
6. The result is displayed. Read out the result, save it if required, and note the memory codes when necessary.
7. Turn the rotary switch to [Earth resistance] to view the value of the measured resistance.
8. Press the [Start] key and release it. The value of the resistance will be displayed in ohms.
9. Replace the test rods or carry out another measurement.

Example measurement setup:

Measurement setup as follows:

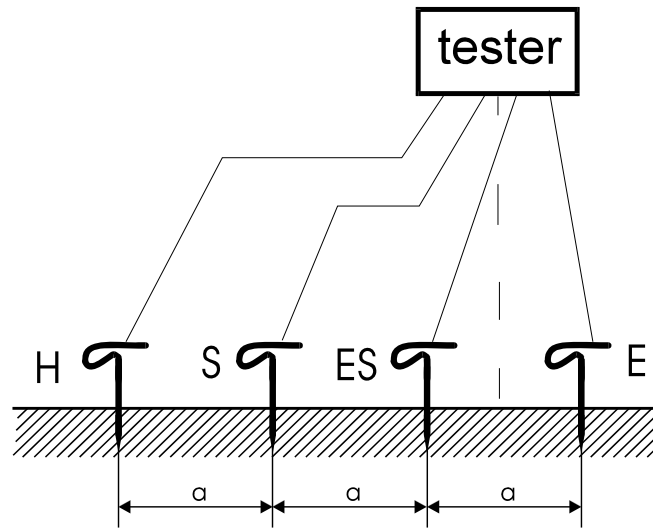

With the included wires the maximal distance of "a" can be 8m

5.3 MEMORISING OF RESULTS







Each saved result is equipped with an identification code defined by the customer. The code consists of 2 x 3 characters as follows:

X.X.X $\xleftrightarrow{\text{DISPLAY}}$ YYY

Where X.X.X represents a code of a certain measuring place inside the tested object, and YYY represents a code of the tested object. Remark: X.X.X is at least one level higher than YYY. For detailed information we refer to the manual delivered with the PATS-W Administration-Software. Each displayed result can be stored as follows:

Pressed key

Comments

1.  The last **changed** partial code (X.X.X. of YYY) which is used for the memorising of the results will, if necessary, be saved in the order of changing.
2.  ,  Insert new codes using the [\uparrow , \downarrow] keys if necessary.
3.  ,  ,  Check the other part of the code pressing the [DISPLAY] key and change it using the [\uparrow , \downarrow] keys if necessary.
4.  Confirm saving by using the [Save Result] key.

The displayed value is now saved to a memory location including the sub results and the parameters of the measurement that can be checked by using the [DISPLAY] key when it is set into the [Recall Result]-function. The list of the sub results and the parameters, which are saved to memory together with the main result, are shown in the following table:

Table 3: Sub results and parameters.

Main result	Subresults and parameters
Earth (clamp) resistance	-
Earth resistance R	-
Soil earth resistivity	a



- If one wishes to abandon the current procedure (memorising), the rotary switch must be turned.
- For all measuring results, numbers from 001 up to including 999 are available (for the object and for the measuring place).
- If one does not care numeration of objects, then all the results can be saved under the same object code. Only the measuring place code has to be changed from test to test.
- If one does not care numeration of objects as well as measuring places, then all the results can be saved under the same object and measuring place code, simply by omitting steps 2 and 3 of the upper demonstration.

5.4 RECALLING OF MEMORISED RESULTS.

Each memorised result is equipped with an eventual sub result and parameters of the measurement (see table 3). Each function has an identification number (1 t/m 3 see figure below). The user is able to identify the function where the sub result belongs to. The identification number is displayed for a while only, before the recalled results are displayed.

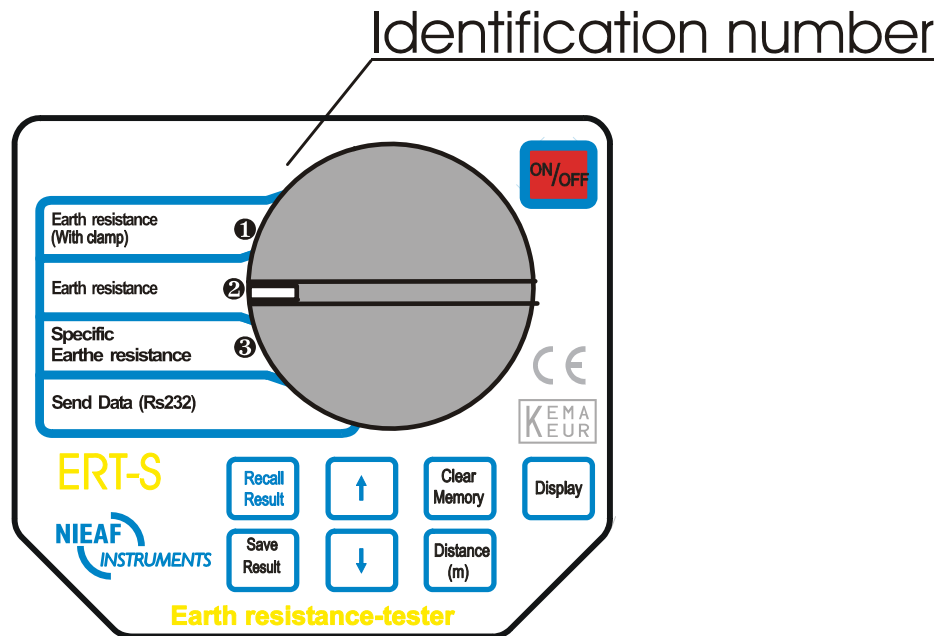
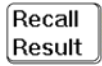

Figure 5: Identification number of each function

Procedure how to recall memorised results:

Pressed key

Comments



The last **changed** partial code (X.X.X of YYY), used for the recalling of results, is displayed.



Insert the desired code by using the [↑, ↓] keys if necessary.

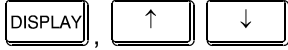

Insert the desired code by using the [↑, ↓] keys if necessary.

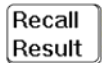

Confirm recalling pressing [Recall Result] key again.

First the identification number of a function is displayed for a while and then the main result will be displayed.



Check the other results saved under the same object and measuring place code by using the [↑, ↓] keys.

Form of the memory locations under a certain code X.X.X, YYY:

Result 1 + sub result;
Result 2 + sub result;
...
...
Result n + sub result

For detail information about codes we refer to the user manual delivered with the PATS-W Administration-Software.



*- If one wishes to abandon the current procedure (recalling), the rotary switch must be turned.
- Use the [DISPLAY] key to check the subresults too.*

5.5 RS232 COMMUNICATION

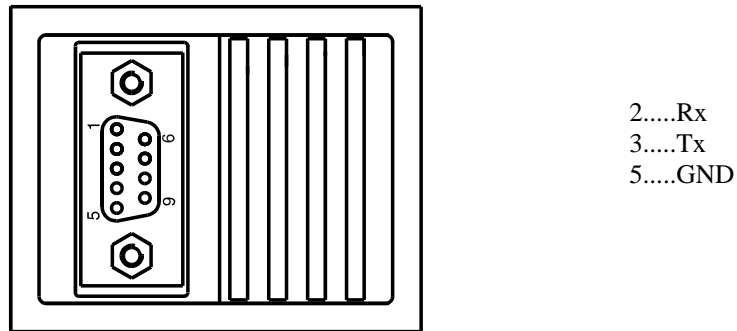

Figure 6: RS232 connector

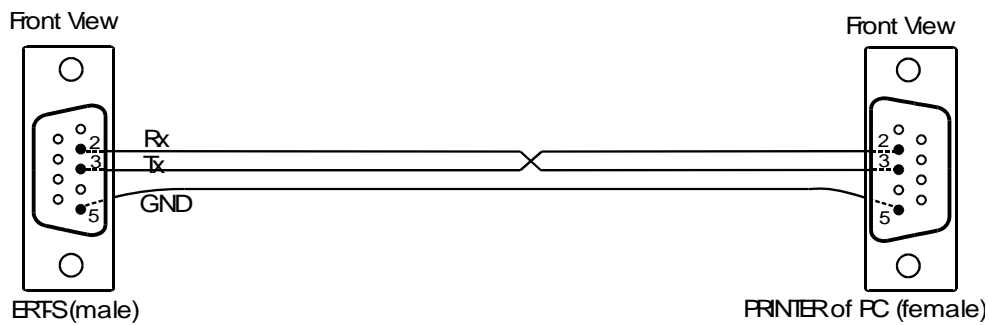

Figure 7: RS232 cable

- connect the printer or the PC to the ELT-S using a RS232 cable, which is supplied with the PATS-W;
- set all communication parameters at the PC by using the PATS-W Administration Software that can be supplied by NIEAF-SMITT upon separate order;
- set the rotary switch of the ELT-S to the RS232-position, “*Pr-t*” will be displayed;
- press the [START] key in order to transfer the stored data to the PC or to the printer;

RS232 parameters

- baud rate 4800 Baud;
- format: 1 start bit, 8 data bits, 1 stop bit, no parity;
- protocol: X_{ON}/X_{OFF}.

```
Type Tester
Serial. Nr.      9621002
-----
Date: -----
Operator: -----
Place: -----
Note: -----

Object: 001      Place: 001
-----
Test 1
Testresult
```

Figure 8: An example of print out



- If one wishes to stop transmission, the rotary switch position must be changed.

5.6 ERASING OF RESULTS

In order to avoid confusion, it is advisable to erase all stored results before starting new family of measurements. Sometimes only results stored under a certain object number or measuring place of the object are to be erased, or even only a recalled result has to be erased. To prevent confusion it is important to follow the erasing procedure correctly.

All results are to be erased

Set the rotary switch in any position but the RS232 position.

Pressed key

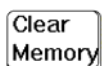

Comments

[I r] is flashing.

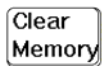

By pressing this key again, the clearing will be confirmed.

All results will be erased.

Only results of a certain object (YYY) are to be erased.

Set the rotary switch in any position but the RS232 position.

Pressed key

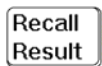

The last changed partial code (X.X.X of YYY), used for the recalling of the results, is displayed.



Use the [DISPLAY] key to select an object code (without dots) if necessary.



Insert the desired code by using the [\uparrow , \downarrow] keys if necessary.

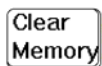

“**[I r]**” is flashing.

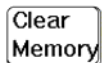

By pressing this key again, the clearing will be confirmed.

Only results of a certain measuring place (X.X.X) of the object are to be erased.

The rotary switch in any position but the RS232 position.

Pressed key

Comments

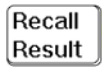

The last changed partial code (X.X.X of YYY), used for the recalling of the results, is displayed.



Insert the desired object / measuring place code by using the [↑, ↓] keys.



Use the [DISPLAY] key to select a measuring place / object code.



Insert desired object / measuring place code by using the [↑, ↓] keys if necessary.



Use the [DISPLAY] key to select the already inserted measuring place code (with dots) if it is not already selected.

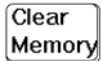

“ r “ is flashing.

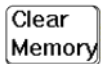

By pressing this key again, the clearing will be confirmed.

Only results of a certain measuring place of the object will be erased.

Only recalled result displayed is to be erased

Set the rotary switch in any position but the RS232 position.

Execute the following acts:

1. Recall the result under a certain measuring place and object code - follow the procedure under paragraph 5.6..
2. Use the [↑, ↓] keys to select the result which has to be erased.
3. Press the [Clear memory] key, “ r “ is flashing.
4. Press the [Clear memory] key again to confirm the erasing.

Only the recalled result under a certain measuring place of the object is erased now. The next result saved under the same measuring place and object code is displayed.



- If one wishes to abandon the current procedure (recalling / clearing), the rotary switch position must be changed.

5.7 RESET OF THE INSTRUMENT

After inserting the batteries or if there is a malfunction noticed, it is advisable to reset the instrument.
How to reset?

1. Switch off the instrument.
2. Press the [Clear memory] key and keep it pressed while you're switching on the instrument.
3. **rES** is displayed for a while meaning the reset function has been effected.



- Performing the reset function means that all memory locations will be erased.

Parameters of all functions will be set to it's default values as follows:



- the nominal voltage for [R_{INS}] function is set to 100V;
- the compensation of the test cords resistance is erased;
- the measuring place identification number is set to 0.0.1;
- the object identification number is set to 001.

5.8 TROUBLESHOOTING

Table 4 describes the different displayed fault messages of the tester. For each fault an explanation and cause is given. Faults, which demand technical qualified persons, are marked with a star (*).

When executing various tests, various warnings could be displayed. They are having the following meanings

Table. 4. General faults and warnings

Display	Cause
O.r.	Result is out of measuring range, see paragraph Specifications. Over range
	Disturbing voltage (noise) is higher than approx. 20Veff.
rC	Current spike resistance is too high, see paragraph Specifications. Alternating with the measured value.
rP	Potential spike resistance is too high, see paragraph Specifications. Alternating with the measured value.
BAT	Battery voltage is lower than 4.3V → replace the batteries.
mem NO	All memory locations are empty.
00.1	Measuring identification number. (With dots)
00 1	Object identification number. (Without dots)
top	Full memory.
Prt	Print function is active
Clr	Clear function is active
rES	Reset of the instrument has been carried out or new batteries are inserted.
	The ES and S terminals are changed → change them.

5.9 CALIBRATION AND REPAIR

To warrant the technical specifications of the tester, we will advise you to calibrate the instrument at least once a year. It's to be shown that the tested products are governed by an established test procedure.

The calibration will be executed by Nieaf-Smitt b.v..In the calibration report the results, judgements, town, date and name of the responsible person will be mentioned. There are no user replaceable parts in the instrument (batteries excepted)!

For calibration and/or service you can send your tester post-paid to your local dealer.

6. MAINTENANCE

	<p><i>Don't replace parts yourself but call technical qualified persons</i></p> <p><i>(see paragraph 2.1.2).</i></p>
---	--

6.1 BATTERIES REPLACEMENT

	<p><i>Exchange all four batteries. If there are memorised results in the instrument and the "BAT" mark appears then transfer them to an external printer or PC first. The batteries have to be changed within one minute!</i></p>
---	---

	<p><i>Disconnect all cables (test cable or RS232 cable) before removing the battery cover.</i></p> <p><i>Caution, possible live parts under the battery cover</i></p> <p><i>Throw, after using, the empty batteries in special the battery basket.</i></p>
--	--

If the "BAT" mark appears at the display, it means that the battery voltage is lower than 4,3 V. Remove the old batteries and insert new ones. Procedure batteries replacement:

1. Disconnect all cables and cords, and remove the battery cover.
2. Remove the old batteries.
3. Place the new batteries in the battery holder. Always exchange all four batteries simultaneously.

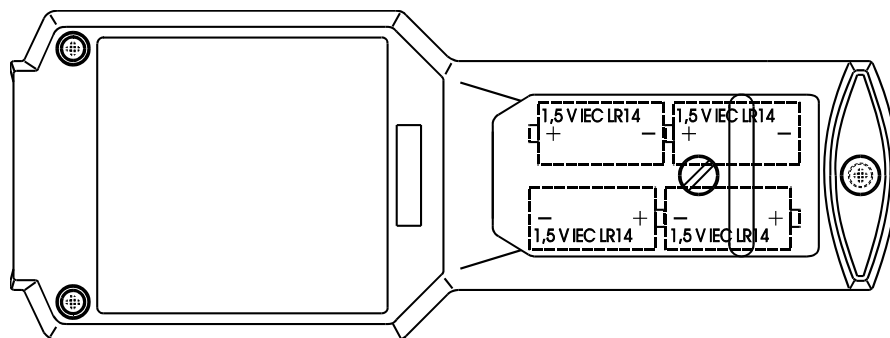



Figure 9: Batteries inserted



Use the batteries declared in technical specification only.

If there is no chance to transfer the results (extern printer or PC not available), then follow the next procedure when changing batteries in order not to loose any stored data:

1. Switch off the instrument.
2. Remove the battery cover.
3. Exchange the batteries within one minute.
4. Place the battery cover back and switch on the instrument
5.  should not be displayed after switching it on. The memorised results have not been erased now.

6.2 CLEANING



*Do not use liquids based on petrol!
Do not spill cleaning liquid over the instrument.*

Use soft patch moister by water or alcohol, and leave the instrument to dry totally after the cleaning.

7. ACCESSORY AND REPLACEABLE PARTS

Supplied standard set:

- one English user manual;
- E test cord (black length 4,5 m);
- ES test cord (green length 4,5 m);
- S test cord (red length 15 m);
- H test cord (blue length 20 m);
- earth rod, 4 pieces;
- test cord support, 4 pieces;

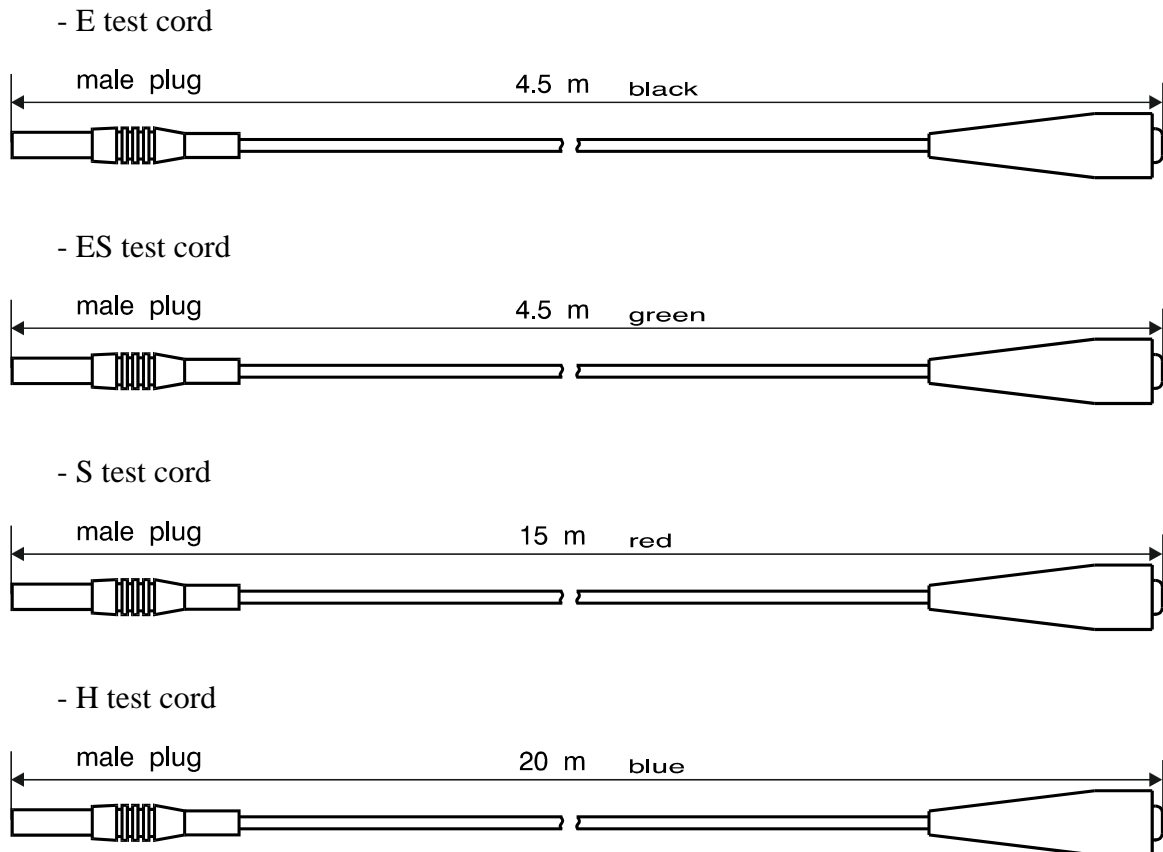

Figure 10: Test cords

Check all the supplied items (enclosure of the instrument as well as the accessories). If there are any damages please return the tester to the supplier for exchange or service.

Supplied options:

- RS232 cable, for data transfer;
- PATS-W Administration-Software;
- E-Test Software (free from internet www.nieaf-instruments.com)
- Test clamp 1000:1 (Other clamps on request)
- Carrier bag;
- Carrier suitcase.

EU-DECLARATION OF CONFORMITY

Product: Earth Resistance Tester

Identification of the instrument:

Trademark: Nieaf Instruments
Model/Type: ERT-S

Nieaf-Smitt herewith declare that the instrument which this declaration refers to is in conformity with the following standards and according to the conditions of following Directives:

Low Voltage Directive (73/23/EEG) as last amended.
EMC-Directive (89/336/EEG) as last amended.

VDE0701
IEC1010-1
EN 55022 class B
NEN-EN 50081-1
NEN-EN 50082-1
IEC801-2 level 3
IEC801-3 level 2
IEC801-4 level 4

Place and date of issue

Name and signature or equivalent stamp of authorised person.

Circuit diagrams

- Two point earth resistance measurement

Connect the instrument to the test object or installation according to the circuit diagram.

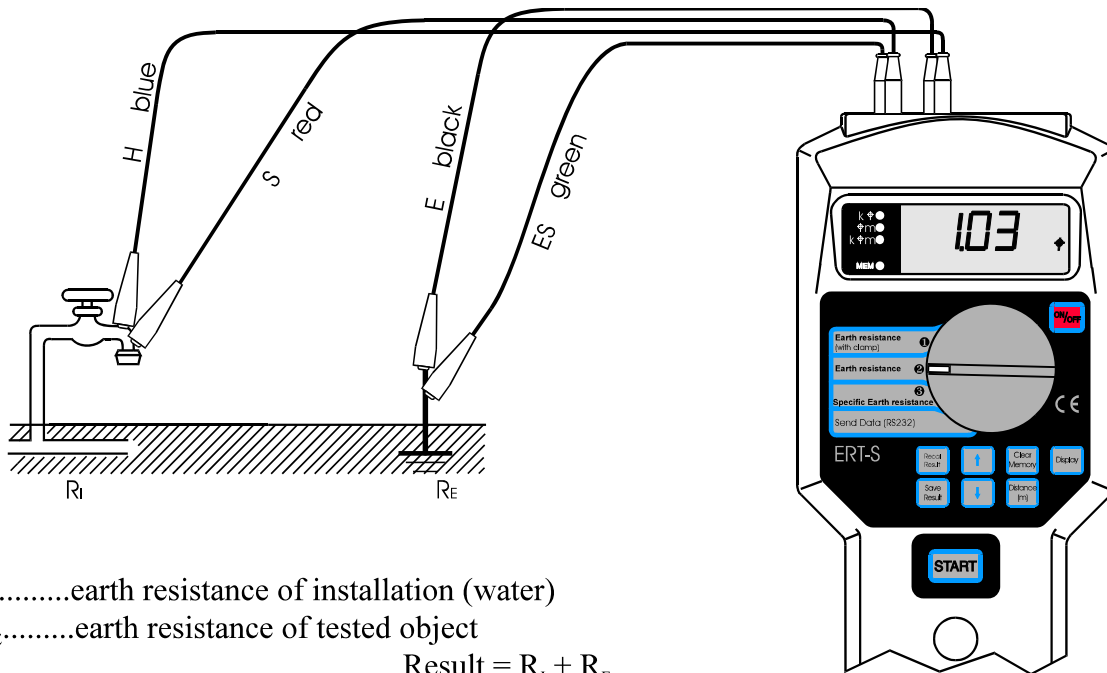

R_i.....earth resistance of installation (water)

R_E.....earth resistance of tested object

$$\text{Result} = R_i + R_E$$

- Three point earth resistance measurement

Connect the instrument to the test object or installation according to the circuit diagram.

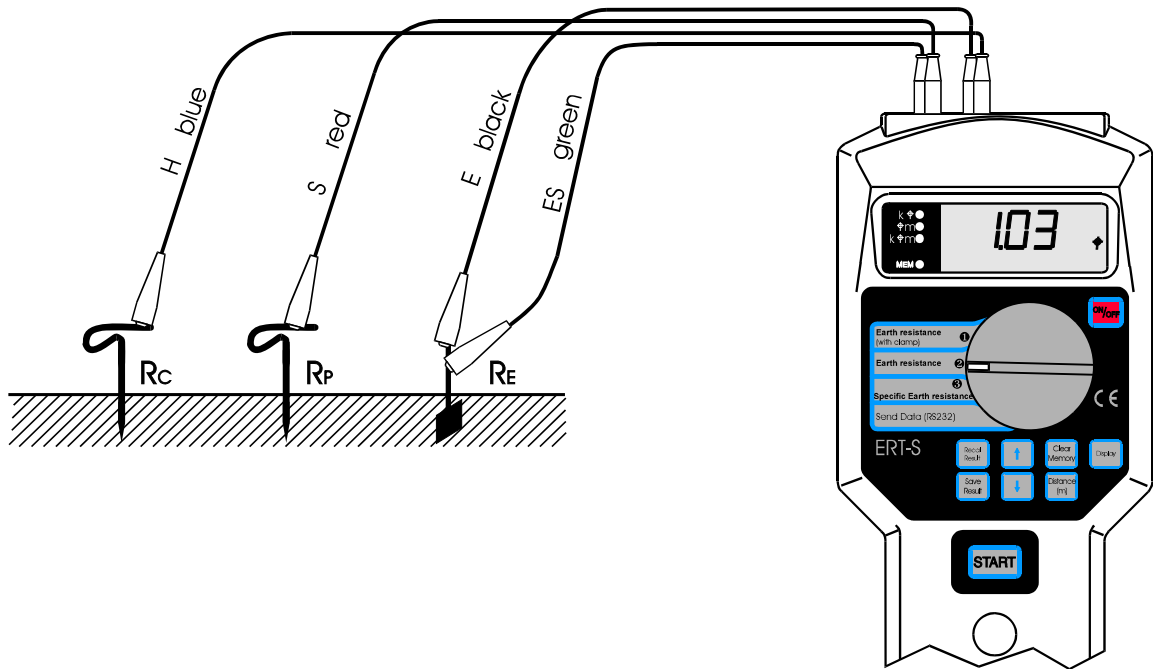

- Clamp system earth resistance measurement

Connect the instrument to the test object or installation according to the circuit diagram.

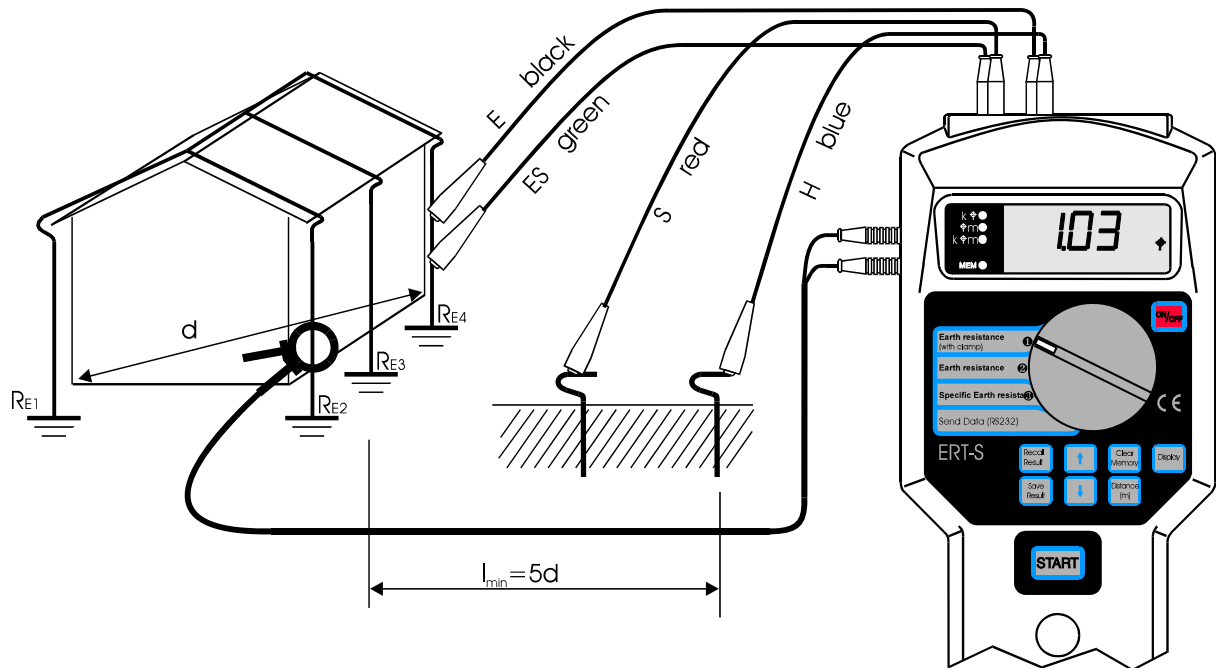

- Soil resistivity test ('Wenner'-method)

Connect the instrument to the test object or installation according to the circuit diagram.

