

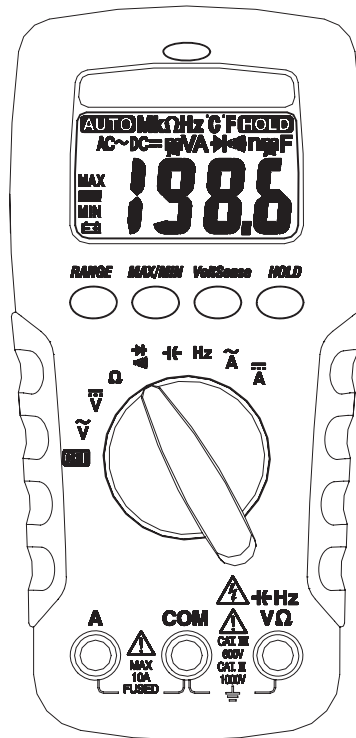

NI 61/62 Digital Multimeter





⚠ Safety Information

Understand and follow operating instructions carefully. Use the meter only as specified in this manual; otherwise, the protection provided by the meter may be impaired.

⚠ WARNING

- When using test leads or probes, keep your fingers behind the finger guards.
- Remove test lead from Meter before opening the battery door or Meter case.
- Use the Meter only as specified in this manual or the protection by the Meter might be impaired.
- Always use proper terminals, switch position, and range for measurements.
- Never attempt a voltage measurement with the test lead inserted into the A input terminal.
- Verify the Meter's operation by measuring a known voltage. If in doubt, have the Meter serviced.
- Do not apply more than the rated voltage, as marked on Meter, between terminals or between any terminal and earth ground.
- Do not attempt a current measurement when the open voltage is above the fuse protection rating. Suspected open circuit voltage can be checked with voltage function.
- Only replace the blown fuse with the proper rating as specified in this manual.
- Use caution with voltages above 30 Vac rms, 42 Vac peak, or 60 Vdc. These voltages pose a shock hazard.
- To avoid false readings that can lead to electric shock and injury, replace battery as soon as low battery indicator  appears.
- Disconnect circuit power and discharge all high-voltage capacitors before testing resistance, continuity, diodes, or capacitance.
- Do not use Meter around explosive gas or vapor.
- To reduce the risk of fire or electric shock do not expose this product to rain or moisture.

Measuring AC/DC Voltage And Frequency

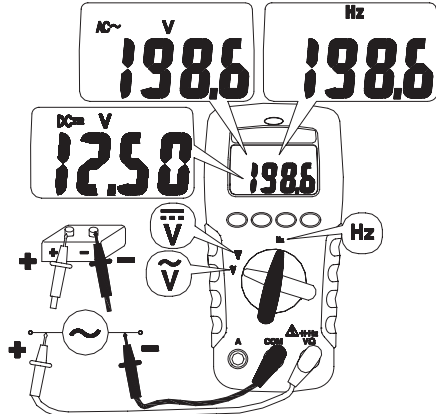

Testing for Continuity and Diode

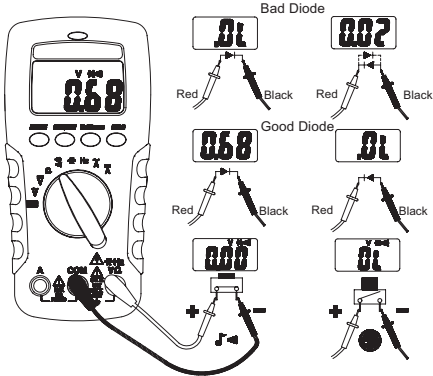

Resistance and Capacitance
(Capacitance for 62 only)

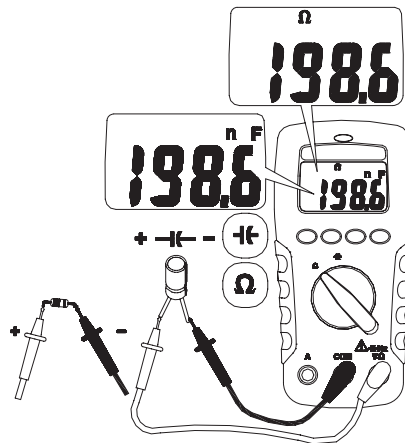

Note – To improve the measurement accuracy of small value capacitor, record the reading with the test leads open then subtract the residual capacitance of the Meter and leads from measurement.

$$C_{UNKNOWN} = C_{MEASUREMENT} - C_{RESIDUAL}$$

MIN MAX Record (For 62 only)

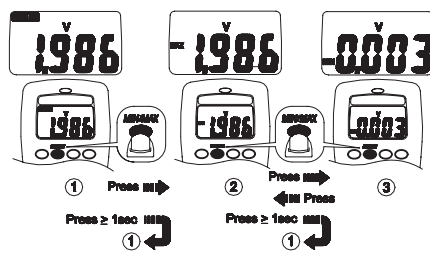



Measuring DC / AC Current (For 62 only)

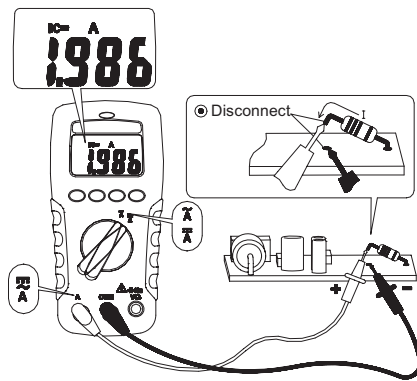

Display Hold

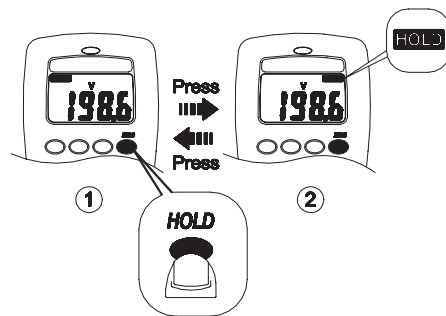



Manual Ranging and Auto Ranging

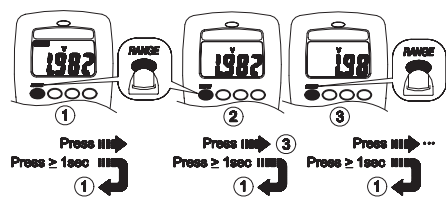

Auto Power Off (Battery Saver)

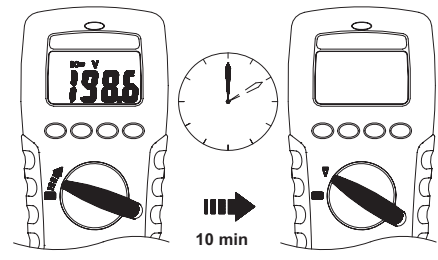

Disable Auto Power Off

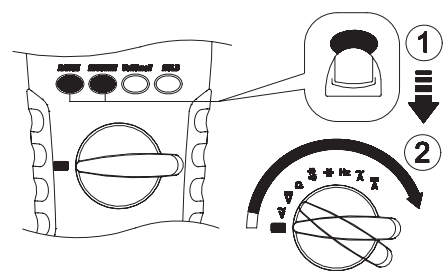

Non-Contact Voltage (Volt sense)

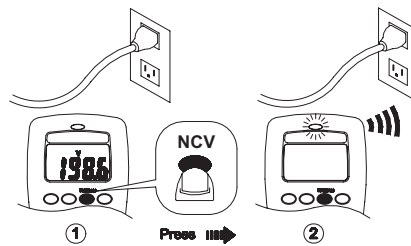

1. Volt sense switch will be activated on any function or at OFF status.
2. Test leads are not used for the Volt sense test.
3. Press the Volt sense button. The display goes black, a tone sounds and the red LED lights up to verify the instrument is operational. The Volt sense button must be held down to detect the presence of voltage without use of the leads.
4. If a voltage of 50V to 600V (50 to 500Hz) is detected near the top of meter a continuous tone sounds and the red LED near the top of meter illuminates.

Fuse Replacement (For 62 only)

Refer to the following figure to replace fuse :

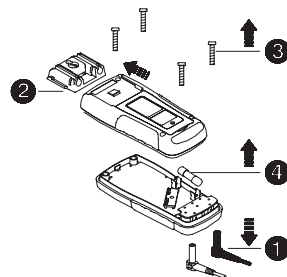

⚠ Caution

- Use only a fuse with the amperage, interrupt, voltage, and speed rating specified.
- Fuse rating :10A, 500V

Battery Replacement

Refer to the following figure to replace the batteries :

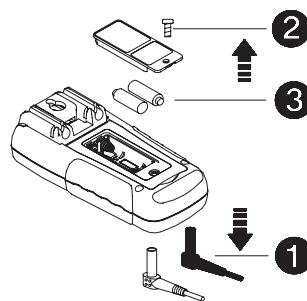

⚠ Caution

- Replace the batteries as soon as the low batteries indicator "⚡" appears, to avoid false reading.
- Batteries 1.5V x 2

Specifications

General Specifications

Display : 2000 counts.

Polarity Indication : Automatic, positive implied, negative indicated.

Overrange Indication : "OL" or "-OL".

Batteries Life : Alkaline 250 hours

Low Batteries Indication :

" E_3 " is displayed when the batteries voltage drops below operating voltage.

Auto Power Off : Approx 10 minutes.

Operating Ambient : Non-condensing $\leq 50^\circ\text{F}$,

$51.8^\circ\text{F} \sim 86^\circ\text{F}$ ($\leq 80\%$ R.H) $87.8^\circ\text{F} \sim 104^\circ\text{F}$

($\leq 75\%$ R.H), $105.8^\circ\text{F} \sim 122^\circ\text{F}$ ($\leq 45\%$ R.H)

Storage Temperature : -4°F to 140°F , 0 to 80% R.H. when battery removed from Meter.

Temperature Coefficient :

$0.15 \times (\text{Spec. Accy}) / ^\circ\text{F}$, $< 64.4^\circ\text{F}$ or $> 82.4^\circ\text{F}$.

Measure : Samples 2 times per second nominal.

Altitude : 6561.7 ft (2000m)

Safety : Complies with EN61010-1, UL61010-1, IEC 61010-1,

V/ Ω : CAT.III. 600V, CAT.II. 1000V.

A : CAT.III. 500V (for 62/62T/62R only)

Pollution degree : 2

Power Requirements :

1.5V x 2 IEC LR03, AM4 or AAA size

Dimensions (W x H x D) :

74mm x 156mm x 44mm

Weight : (320g) including battery.

Accessories : Battery (installed), Test leads and user manual.

Electrical Specifications

Accuracy is \pm (% reading + number of digits) at 23°C \pm 5°C < 80%RH.

DC / AC Volts

Range	AC Accuracy
200.0mV *	Unspecified
2.000V *	\pm (1.5%+5dgt) 50Hz ~ 300Hz
20.00V ~ 200.0V *	\pm (1.5%+5dgt) 50Hz ~ 500Hz *
750V AC / 1000V DC	

DC Accuracy : \pm (0.5% + 2dgt)

Over voltage protection :

1000V DC or 750 V ACrms.

Input Impedance : 10M Ω // less than 100pF.

* CMRR / NMRR :

(Common Mode Rejection Ratio)

(Normal Mode Rejection Ratio)

V_{AC} : CMRR > 60dB at DC, 50Hz / 60Hz

V_{DC} : CMRR > 100dB at DC, 50Hz / 60Hz

NMRR > 50dB at DC, 50Hz / 60Hz

AC Conversion Type :

Average sensing rms indication.

AC conversions are ac-coupled, true rms responding, calibrated to the sine wave input.

* The minimum LCD reading is 1400 count in Auto Ranging Mode.

Crest Factor : C.F. = Peak / Rms

+ 1.5% addition error for C.F. from 1.4 to 3

+ 3% addition error for C.F. from 3 to 4

DC / AC Current (For 62 only)

Range	DC Accuracy	AC Accuracy
2.000A	\pm (1.0% + 3 dgt)	\pm (1.5% + 5 dgt) 50Hz ~ 500Hz *
10.00A **		

Voltage Burden : 2V max.

Overload Protection :

A input : 10A (500V) fast blow fuse

* **AC Conversion Type** : Conversion type and additional specification are same as DC/AC Voltage.

**** Ampere Testing Duty Ratio Table**

Ampere	Testing Time	Rest Time
10A	1min	10min
9A	2min	10min
8A	3min	10min
7A	4min	10min
6A	5min	10min
5A	Continually	N/A

Resistance

Range	Accuracy	Voltage Burden
200.0 ~ 200.0K Ω **	$\pm(0.7\% + 3 \text{ dgt})$	2V max
2.000M Ω **	$\pm(1.0\% + 3 \text{ dgt})$	
20.00M Ω *	$\pm(1.5\% + 3 \text{ dgt})$	

Open circuit Voltage : -1.3V approx.

* <100 dgt rolling.

** The minimum LCD reading is 1400 count in Auto Ranging Mode.

Diode Check and Continuity

Range	Resolution	Accuracy
	10 mV	$\pm(1.5\% + 5 \text{ dgt})^*$

* For 0.4V ~ 0.8V

Max. Test Current : 1.5mA

Max. Open Circuit Voltage : 2V

Overload Protection : 600V rms.

Frequency (For 62 only)

Range	Sensitivity	Accuracy
2000Hz ~200.0KHz	>1.5 Vac rms, <5 Vac rms	Frequency : 0.01%±1dgt
2.000MHz ~ 20.00MHz	>2 Vac rms, <5 Vac rms	

Overload Protection : 600V rms.
Minimum pulse width : >25 ns
Duty cycle limits : >30% and <70%

Capacitance (For 62 only)

Range	Accuracy	Overload Protection
2.000nF ~ 200.0µF	±(1.9% + 8 dgt)	600V rms
2.000mF *		

* < 10 dgt of reading rolling.



Limited Warranty

This thermometer is warranted to the original purchaser against defects in material and workmanship for 1 year from the date of purchase. During this warranty period, manufacturer will, at its option, replace or repair the defective unit, subject to verification of the defect or malfunction. This warranty does not cover disposable batteries, or damage from abuse, neglect, accident, unauthorized repair, alteration, contamination, or abnormal conditions of operation or handling. Any implied warranties arising out of the sale of this product, including but not limited to implied warranties of merchantability and fitness for a particular purpose, are limited to the above. The manufacturer shall not be liable for loss of use of the instrument or other incidental or consequential damages, expenses, or economic loss, or for any claim or claims for such damage, expense or economic loss. Some states or countries laws vary, so the above limitations or exclusions may not apply to you.







Nieaf-Smitt B.V.
Vrieslantlaan 6, 3526 AA, Utrecht
P.O. Box 7023, 3502 KA, Utrecht,
The Netherlands
Tel.: +31 (0) 30 288 13 11
Fax: +31 (0) 30 289 88 16
E-mail: sales@nieaf-smitt.nl
Internet:
<http://www.nieaf-smitt.nl>