

## /// Plug-in timer relay, delay-off with 4 C/O contacts

Rugged plug-in relays for extreme reliability, within long endurance applications and harsh environments

### TDE4N

Timer relay, delay-off  
Part of D-platform



(TDE4N-U is shown)

#### Description

Plug-in electronic industrial timer relay with four change-over contacts. When the relay is de-energized there is a delay on drop-out without any auxiliary power supply. The delay time is adjustable with a lockable knob. The relay can also be supplied with a fixed time delay (no knob).

The relay is equipped with a LED which indicates the presence of energizing voltage. Standard equipped with back EMF suppression. Optionally equipped with magnetic arc blow-out for high breaking capacity and long contact life.

The construction of the relay and choice of materials makes the TDE4N relay suitable to withstand low and high temperatures, shock & vibrating and dry to humid environments.

No external retaining clip needed as integrated 'snap-lock' will hold relay into socket under all circumstances and mounting directions. Compact design, choice of many options and a wide range of sockets makes the TDE4N relay an easy and flexible solution to use.

#### Application

Rugged plug-in relays for extreme reliable, long endurance applications in harsh environment. These relay series are designed for demanding industrial applications such as power utilities and petrochemical industries.

The TDE4N is used in applications where a time delay on drop-out is necessary after de-energizing the relay, without using auxiliary supply.

#### Features

- Time delay relay
- Delay on drop-out (without auxiliary power supply)
- Compact plug-in design
- 4 C/O contacts
- Delay time adjustable by lockable knob
- Also available with fixed time delay
- Total time delay range: 0 s...180 s
- Back EMF suppression
- One LED for voltage presence
- Suitable for AC and DC voltage
- Flat, square and silver plated relay pins for excellent socket connection
- Wide range sockets
- Integrated snap lock

#### Connection diagram

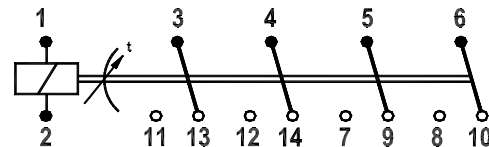

Please note the relay will leave production in open state (with open armature) with all contacts in the position shown in the connection diagram. Due to severe shocks far exceeding maximum levels mentioned in IEC 61373 (Category I, Class B, Body mounted), it can happen the armature closes and stay closed. Therefore after installation all relays must be checked on correct state of the contacts and apply rated voltage to the coil to check correct operation.

#### Timing diagrams

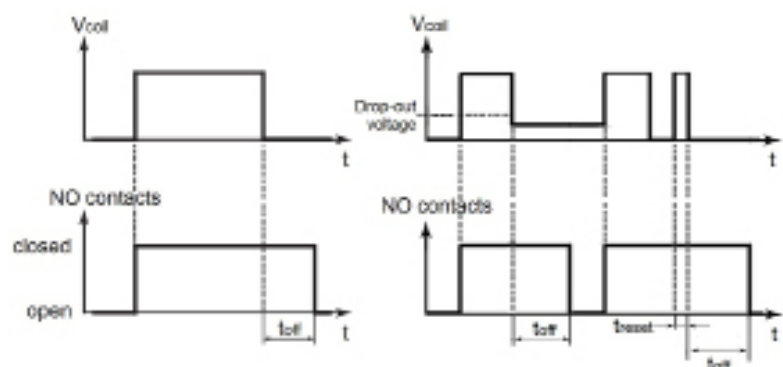

#### Compliance

IEC 61812-1  
IEC 60947  
IEC 60947-5-1  
IEC 60255  
EMC Directive



## Timer relay TDE4N

### Options

- Magnetic arc blow-out
- Low temperature (-40 °C)
- Gold plated contacts
- Extra dust protection
- AgSnO<sub>2</sub> contacts, high resistant to welding
- Double make / double break contacts (-40 °C)

### Dimensions (mm)

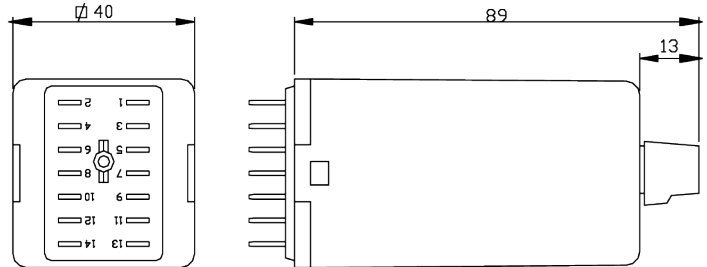

### Sockets

|                     |                        | Mounting       |            |               |     |
|---------------------|------------------------|----------------|------------|---------------|-----|
|                     |                        | Surface / Wall | 35 mm rail | Panel / Flush | PCB |
| Terminal connection | Screw                  | V23            | V23        | -             | -   |
|                     | Screw - wide terminals | V22 BR         | V23 BR     | -             | -   |
|                     | Spring clamp           | V29            | V29        | V33           | -   |
|                     | Faston                 | -              | -          | V31           | -   |
|                     | Crimp                  | -              | -          | V26           | -   |
|                     | Solder tag             | -              | -          | V3            | -   |
|                     | PCB                    | -              | -          | -             | V32 |

For more information see the respective datasheets

For more detailed technical specifications, drawings and ordering information, go to the product page on [www.morssmitt.com](http://www.morssmitt.com)

 **Over 10 million Mors Smitt relays in use in applications worldwide!**

**Mors Smitt Asia Ltd.**  
 26/F., Casey Aberdeen House  
 38 Heung Yip Road, Wong Chuk Hang  
 Hong Kong  
 Tel: +852 2343 555  
[sales.msa@wabtec.com](mailto:sales.msa@wabtec.com)

**Mors Smitt France SAS**  
 2 Rue de la Mandinière  
 72300 Sablé-sur-Sarthe, France  
 Tel: +33 (0) 243 92 82 00  
[sales.msf@wabtec.com](mailto:sales.msf@wabtec.com)

**Mors Smitt UK**  
 Graycar Business Park  
 Burton on Trent, DE13 8EN, UK  
 Tel: +44 (0)1283 357 263  
[sales.msuk@wabtec.com](mailto:sales.msuk@wabtec.com)

**Wabtec Netherlands B.V.**  
 Darwinstraat 10  
 6718 XR Ede, Netherlands  
 Tel: +31 (0)88 600 4500  
[sales.msbv@wabtec.com](mailto:sales.msbv@wabtec.com)

**Mors Smitt Technologies Ltd.**  
 1010 Johnson Drive  
 Buffalo Grove, IL 60089-6918, USA  
[salesmst@wabtec.com](mailto:salesmst@wabtec.com)

**RMS Mors Smitt**  
 19 Southern Court  
 Keysborough, VIC 3173, Australia  
 Tel: +61 (0)3 8544 1200  
[sales.rms@wabtec.com](mailto:sales.rms@wabtec.com)

(c) Copyright 2022

All rights reserved. Nothing from this edition may be multiplied, or made public in any form or manner, either electronically, mechanically, by photocopying, recording, or in any manner, without prior written consent from Mors Smitt. This also applies to accompanying drawings and diagrams. Due to a policy of continuous development Mors Smitt reserves the right to alter the equipment specification and description outlined in this datasheet without prior notice and no part of this publication shall be deemed to be part of any contract for the equipment unless specifically referred to as an inclusion within such contract. Mors Smitt does not warrant that any of the information contained herein is complete, accurate, free from potential errors, or fit for any particular purpose. Mors Smitt does not accept any responsibility arising from any party's use of the information in this document.

## Technical specifications

### Time delay characteristics

|   |                           |   |
|---|---------------------------|---|
| Time delay function   |                           | Delay on drop-out (without auxiliary power supply), delay starts when drop-out value is reached.                            |
| Available time ranges   | Fixed                     | Any value between 0...180 s with resolution of 0.1 s  |
|   | Adjustable*               | 0...1 s    0...3 s    0...6 s    0...10 s    0...30 s<br>0...60 s    0...100 s    0...180 s<br>Other time ranges on request |
| Accuracy  | Adjustment                | < 10 % of full scale<br>After adjusting / fixed time setting: no variation in setpoint                                      |
|   | Repeatability             | Fixed: 1 % of fixed value<br>Adjustable: 1 % of full scale value  |
| Time variation  | vs. voltage variations    | $\pm 0.1 \% / \% U_{nom}$ of set value $\pm 50$ ms  |
|   | vs. temperature variation | $\pm 0.02 \% / K$ of set value  |
| Recovery time   |                           | 0 s   |
| Pull-in time  |                           | < 100 ms  |
| Release time  |                           | Depending on drop-out time setting  |
| <p>Example time delay : Time range 0 - 3 s. Time delay manually set on 2 s : delay will be between 1.7 s - 2.3 s.<br/>         For example: 2.0 s, accuracy due to repeatability, voltage and temperature variation:<br/>         The ambient temperature is 30 °C which is 10 degrees different compared to the standard 20 °C. This results in 0.2 % extra time variation.<br/>         The applied voltage is 15 % lower than the nominal voltage. This results in 1.5 % extra time variation. The total maximum time variation is:<br/>         1.0 % (repeatability) x 3 = 0.03 s<br/>         + 0.2 % (temperature variation) x 2 = 0.04 s<br/>         + 1.5 % (voltage variation) x 2 = 0.03 s<br/>         = 0.10 s<br/>         In this case every new delay time will be between 1.90 s and 2.10 s</p> |                           |   |

#### Remarks:

- Inside the TDE4N is a bistable relay controlled by electronics; the relay can stay in energized mode after removing the control voltage in case the electronics are damaged (e.g. due to a power surge)
- For safety-critical applications we recommend TDBE4 model, which doesn't use a bistable relay inside

### Coil characteristics

|  |   |
|--|---|
| Minimum operate pulse time                       | 100 ms  |
| Operating voltage DC and AC                      | 50 Hz and 60 Hz   |
| Guaranteed drop-out voltage                      | 6 V (24-60 V version), 23 V (72-250 version)            |
| Nominal current                                  | < 3 mA (24-60 V version), < 2 mA (72-250 V version)     |
| Inrush current (< 100 ms)                        | < 750 mA (24-60 V version), < 350 mA (72-250 V version) |
| Reset internal timer when delay-off is activated |   |
| - Minimum reset pulse, $t_{reset}$ , adjustable  | 0.1 % of time range + 20 ms                             |
| - Minimum reset pulse, $t_{reset}$ , fixed       | 0.2 % of time range + 20 ms                             |

| Type  | $U_{nom}$ (VAC/DC) | $U_{min}$ (VAC/DC) | $U_{max}$ (VAC/DC) |
|-------|--------------------|--------------------|--------------------|
| TDE4N | 24-60              | 19.2               | 66                 |
|       | 72-250             | 57.6               | 275                |

#### Remarks:

- $U_{min}$  is the must-operate voltage at which the relay has picked up in all circumstances (worst-case situation), in practice the relay picks up at a lower voltage

## Timer relay TDE4N

### Contact characteristics

|                                      |            |   |
|--------------------------------------|------------|---|
| Amount and type of contacts          |            | 4 C/O   |
| Maximum make current                 |            | 16 A  |
| Peak inrush current (make and carry) | NF F62-002 | 200 A for 10 ms<br>40 A for 0.5 s<br>30 A for 1 s         |
| Maximum continuous current           |            | 10 A  |
| Maximum switching voltage            |            | 250 VDC, 440 VAC  |
| Minimum switching voltage            |            | 12 V  |
| Minimum switching current            |            | 10 mA   |
| Maximum breaking capacity            |            | 110 VDC, 8 A (L/R ≤ 15 ms)<br>230 VAC, 10 A (cos φ ≥ 0.7) |
| Contact resistance                   |            | 15 mΩ (initial)   |
| Material                             |            | Ag standard (optional AgSnO <sub>2</sub> , Au on Ag)      |
| Contact gap                          |            | 0.7 mm  |
| Contact force                        |            | > 200 mN  |

### Electrical characteristics

|                     |               |                      |
|---------------------|---------------|----------------------|
| Dielectric strength | Pole-pole     | 4 kV, 50 Hz, 1 min   |
|                     | Cont-coil     | 2.5 kV, 50 Hz, 1 min |
|                     | Open contacts | 2.5 kV; 50 Hz; 1 min |
| Pulse withstanding  | IEC 60255-5   | 5 kV (1.2/50 μs)     |

### Mechanical characteristics

|                                 |  |  |
|---------------------------------|--|--|
| Mechanical life                 |  | 10 x 10 <sup>6</sup> operations                  |
| Maximum switching frequency     |  | Mechanical: 3600 ops/h<br>Electrical: 1200 ops/h |
| Torque value screw to lock knob |  | 0.2-0.4 Nm                                       |
| Weight                          |  | 190 g (without options)                          |

### Environmental characteristics

|                       |  |   |
|-----------------------|--|---|
| Environmental         |  | IEC 61810   |
| Vibration             |  | IEC 61373, Category I, Class B, Body mounted            |
| Shock                 |  | IEC 61373, Category I, Class B, Body mounted            |
| Operating temperature |  | -25 °C...+70 °C (with option C -40 °C)                  |
| Humidity              |  | 93%   |
| Salt mist             |  | IEC 60068-2-11, NaCl, 35 °C for 4 days                  |
| Damp heat             |  | IEC 60068-2-30, Test method Db variant 1                |
| Protection            |  | IEC 60529, IP40 (relay on socket) (with option K: IP50) |
| Insulation materials  |  | Cover: polycarbonate<br>Base: polyester                 |

## Timer relay TDE4N

### Industry compliancy

|               |  |
|---------------|--|
| IEC 61810     | Electromechanical elementary relays                              |
| IEC 60947     | Low voltage switch gear and control gear                         |
| IEC 60947-5-1 | Electromechanical control circuit devices and switching elements |
| IEC 60255     | Relay design and environmental conditions                        |
| CE            |  |

### Options

| Code | Description | Remark | Cannot be combined with: |
|------|-------------|--------|--------------------------|
|------|-------------|--------|--------------------------|

#### Standard options:

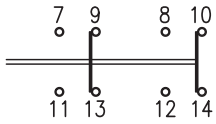
|        |   |   |   |
|--------|---|---|---|
| B      | Magnetic arc blow-out.  | Ensures a high DC breaking capacity and longer contact life   |   |
| C      | Low temperature (-40 °C)  | Icontact < 8 A  |   |
| E*     | Au; Gold plated contacts (10 µm)  | Yellow tape around relay for identification   | M |
| K      | Extra dust protection   | IP50 Cat 2 for the relays mounted in a Mors Smitt socket. Application PD1/PD2 and contact load > 0.5 A.     |   |
| Y      | Double break / double make contacts. Breaking capacity increased by 50% and longer contact life. To further increase the breaking capacity and contact life this option can be combined with option B | 2 C/O DM/DB, -40 °C<br> |   |
| Keying | Coil coding relay and socket  |   |   |

#### Special options:

|   |  |                               |   |
|---|--|-------------------------------|---|
| M | AgSnO <sub>2</sub> ; "non-weldable" contacts | Min. contact contact > 100 mA | E |
|---|--|-------------------------------|---|

#### \* Gold plated contacts characteristics

|                           |   |
|---------------------------|---|
| Material                  | Ag, 10 µm gold plated   |
| Maximum switching voltage | 60 V (higher voltages may be possible, contact Mors Smitt for more information)   |
| Maximum switching current | 400 mA (at higher rate gold will evaporate, then the standard silver contact rating of minimum 10 mA and 12 V is valid) |
| Minimum switching voltage | 5 V   |
| Minimum switching current | 1 mA  |

Remark: For application support or technical product support, contact your local Mors Smitt sales office (see contact details on last page).

## Timer relay TDE4N

### Electrical life expectancy and breaking capacity

The life expectancy values shown below are based on factory tests (test frequency at 1/3 Hz). These values could be different in real life applications as environmental conditions, switching frequencies and duty cycles will influence these values. Putting more contacts in series (Y) will increase breaking capacity and life expectancy significantly.

Breaking capacity relays (Resistive load DC1)

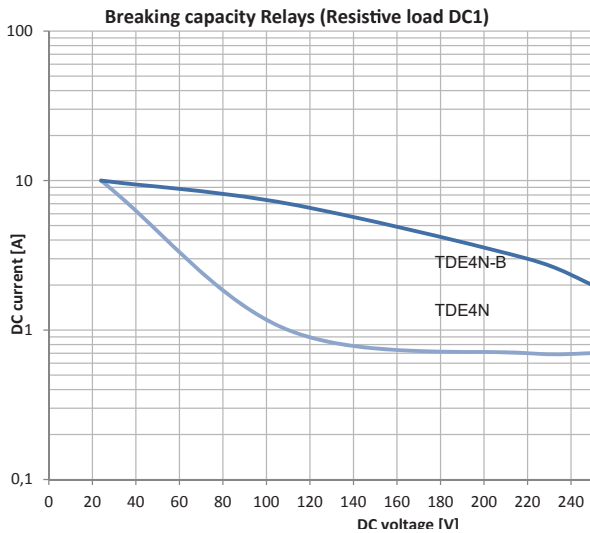

### AC and DC current breaking capacity versus life expectancy in millions of cycles for TDE4N-B. Rate of contacts opening and closing = 1200 operations per hour.

AC Current breaking capacity at  $\cos\phi = 1$

| Curve | 1   | 2   | 3  | 4  |
|-------|-----|-----|----|----|
| VAC   | 220 | 125 | 48 | 24 |

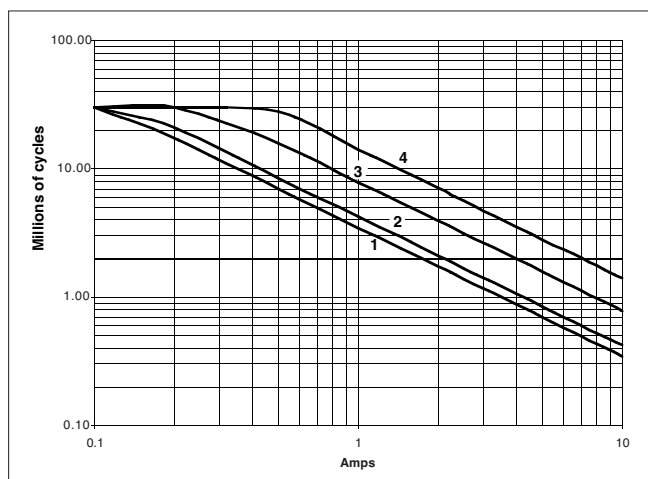

DC Current breaking capacity at L/R = 0

| Curve | 1   | 2   | 3  | 4  |
|-------|-----|-----|----|----|
| VDC   | 220 | 125 | 48 | 24 |

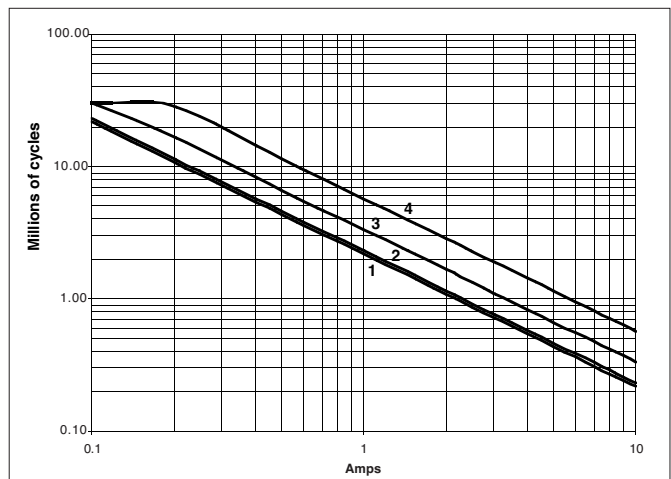

By connecting 2 contacts in series, the DC current breaking capacity is increased by 50%.

## Timer relay TDE4N

In this section the most common breaking capacity for DC-voltage / inductive load possibilities are presented with the different options and contact configurations within the TDE4N-relays

| TDE4N   | TDE4N-B | TDE4N-Y |     |  |         |       |           |         |       |  |         |       |      |         |       |  |         |       |   |     |         |     |  |         |     |           |         |     |  |         |     |      |         |   |  |         |   |  |     |         |       |  |         |     |           |         |       |  |         |       |      |         |   |  |         |   |
|---|---------|---------|-----|--|---------|-------|-----------|---------|-------|--|---------|-------|------|---------|-------|--|---------|-------|---|-----|---------|-----|--|---------|-----|-----------|---------|-----|--|---------|-----|------|---------|---|--|---------|---|--|-----|---------|-------|--|---------|-----|-----------|---------|-------|--|---------|-------|------|---------|---|--|---------|---|
| <ul style="list-style-type: none"> <li>• 4 C/O contacts</li> <li>• Contact gap: 0.7 mm</li> </ul> <p><b>Breaking capacity</b></p> <table> <tr> <td>DC1</td> <td>110 VDC</td> <td>1 A</td> </tr> <tr> <td></td> <td>220 VDC</td> <td>0.7 A</td> </tr> <tr> <td>L/R=40 ms</td> <td>110 VDC</td> <td>0.3 A</td> </tr> <tr> <td></td> <td>220 VDC</td> <td>0.1 A</td> </tr> <tr> <td>DC13</td> <td>110 VDC</td> <td>-</td> </tr> <tr> <td></td> <td>220 VDC</td> <td>-</td> </tr> </table>  | DC1     | 110 VDC | 1 A |  | 220 VDC | 0.7 A | L/R=40 ms | 110 VDC | 0.3 A |  | 220 VDC | 0.1 A | DC13 | 110 VDC | -     |  | 220 VDC | -     | <ul style="list-style-type: none"> <li>• 4 C/O contacts</li> <li>• Magnetic arc blow out</li> <li>• Contact gap: 0.8 mm</li> </ul> <p><b>Breaking capacity</b></p> <table> <tr> <td>DC1</td> <td>110 VDC</td> <td>7 A</td> </tr> <tr> <td></td> <td>220 VDC</td> <td>3 A</td> </tr> <tr> <td>L/R=40 ms</td> <td>110 VDC</td> <td>3 A</td> </tr> <tr> <td></td> <td>220 VDC</td> <td>1 A</td> </tr> <tr> <td>DC13</td> <td>110 VDC</td> <td>-</td> </tr> <tr> <td></td> <td>220 VDC</td> <td>-</td> </tr> </table> | DC1 | 110 VDC | 7 A |  | 220 VDC | 3 A | L/R=40 ms | 110 VDC | 3 A |  | 220 VDC | 1 A | DC13 | 110 VDC | - |  | 220 VDC | - | <ul style="list-style-type: none"> <li>• 2 C/O contacts</li> <li>• Double make double break</li> <li>• Contact gap: 1.4 mm</li> </ul> <p><b>Breaking capacity</b></p> <table> <tr> <td>DC1</td> <td>110 VDC</td> <td>1.5 A</td> </tr> <tr> <td></td> <td>220 VDC</td> <td>1 A</td> </tr> <tr> <td>L/R=40 ms</td> <td>110 VDC</td> <td>0.5 A</td> </tr> <tr> <td></td> <td>220 VDC</td> <td>0.2 A</td> </tr> <tr> <td>DC13</td> <td>110 VDC</td> <td>-</td> </tr> <tr> <td></td> <td>220 VDC</td> <td>-</td> </tr> </table> | DC1 | 110 VDC | 1.5 A |  | 220 VDC | 1 A | L/R=40 ms | 110 VDC | 0.5 A |  | 220 VDC | 0.2 A | DC13 | 110 VDC | - |  | 220 VDC | - |
| DC1   | 110 VDC | 1 A     |     |  |         |       |           |         |       |  |         |       |      |         |       |  |         |       |   |     |         |     |  |         |     |           |         |     |  |         |     |      |         |   |  |         |   |  |     |         |       |  |         |     |           |         |       |  |         |       |      |         |   |  |         |   |
|   | 220 VDC | 0.7 A   |     |  |         |       |           |         |       |  |         |       |      |         |       |  |         |       |   |     |         |     |  |         |     |           |         |     |  |         |     |      |         |   |  |         |   |  |     |         |       |  |         |     |           |         |       |  |         |       |      |         |   |  |         |   |
| L/R=40 ms   | 110 VDC | 0.3 A   |     |  |         |       |           |         |       |  |         |       |      |         |       |  |         |       |   |     |         |     |  |         |     |           |         |     |  |         |     |      |         |   |  |         |   |  |     |         |       |  |         |     |           |         |       |  |         |       |      |         |   |  |         |   |
|   | 220 VDC | 0.1 A   |     |  |         |       |           |         |       |  |         |       |      |         |       |  |         |       |   |     |         |     |  |         |     |           |         |     |  |         |     |      |         |   |  |         |   |  |     |         |       |  |         |     |           |         |       |  |         |       |      |         |   |  |         |   |
| DC13  | 110 VDC | -       |     |  |         |       |           |         |       |  |         |       |      |         |       |  |         |       |   |     |         |     |  |         |     |           |         |     |  |         |     |      |         |   |  |         |   |  |     |         |       |  |         |     |           |         |       |  |         |       |      |         |   |  |         |   |
|   | 220 VDC | -       |     |  |         |       |           |         |       |  |         |       |      |         |       |  |         |       |   |     |         |     |  |         |     |           |         |     |  |         |     |      |         |   |  |         |   |  |     |         |       |  |         |     |           |         |       |  |         |       |      |         |   |  |         |   |
| DC1   | 110 VDC | 7 A     |     |  |         |       |           |         |       |  |         |       |      |         |       |  |         |       |   |     |         |     |  |         |     |           |         |     |  |         |     |      |         |   |  |         |   |  |     |         |       |  |         |     |           |         |       |  |         |       |      |         |   |  |         |   |
|   | 220 VDC | 3 A     |     |  |         |       |           |         |       |  |         |       |      |         |       |  |         |       |   |     |         |     |  |         |     |           |         |     |  |         |     |      |         |   |  |         |   |  |     |         |       |  |         |     |           |         |       |  |         |       |      |         |   |  |         |   |
| L/R=40 ms   | 110 VDC | 3 A     |     |  |         |       |           |         |       |  |         |       |      |         |       |  |         |       |   |     |         |     |  |         |     |           |         |     |  |         |     |      |         |   |  |         |   |  |     |         |       |  |         |     |           |         |       |  |         |       |      |         |   |  |         |   |
|   | 220 VDC | 1 A     |     |  |         |       |           |         |       |  |         |       |      |         |       |  |         |       |   |     |         |     |  |         |     |           |         |     |  |         |     |      |         |   |  |         |   |  |     |         |       |  |         |     |           |         |       |  |         |       |      |         |   |  |         |   |
| DC13  | 110 VDC | -       |     |  |         |       |           |         |       |  |         |       |      |         |       |  |         |       |   |     |         |     |  |         |     |           |         |     |  |         |     |      |         |   |  |         |   |  |     |         |       |  |         |     |           |         |       |  |         |       |      |         |   |  |         |   |
|   | 220 VDC | -       |     |  |         |       |           |         |       |  |         |       |      |         |       |  |         |       |   |     |         |     |  |         |     |           |         |     |  |         |     |      |         |   |  |         |   |  |     |         |       |  |         |     |           |         |       |  |         |       |      |         |   |  |         |   |
| DC1   | 110 VDC | 1.5 A   |     |  |         |       |           |         |       |  |         |       |      |         |       |  |         |       |   |     |         |     |  |         |     |           |         |     |  |         |     |      |         |   |  |         |   |  |     |         |       |  |         |     |           |         |       |  |         |       |      |         |   |  |         |   |
|   | 220 VDC | 1 A     |     |  |         |       |           |         |       |  |         |       |      |         |       |  |         |       |   |     |         |     |  |         |     |           |         |     |  |         |     |      |         |   |  |         |   |  |     |         |       |  |         |     |           |         |       |  |         |       |      |         |   |  |         |   |
| L/R=40 ms   | 110 VDC | 0.5 A   |     |  |         |       |           |         |       |  |         |       |      |         |       |  |         |       |   |     |         |     |  |         |     |           |         |     |  |         |     |      |         |   |  |         |   |  |     |         |       |  |         |     |           |         |       |  |         |       |      |         |   |  |         |   |
|   | 220 VDC | 0.2 A   |     |  |         |       |           |         |       |  |         |       |      |         |       |  |         |       |   |     |         |     |  |         |     |           |         |     |  |         |     |      |         |   |  |         |   |  |     |         |       |  |         |     |           |         |       |  |         |       |      |         |   |  |         |   |
| DC13  | 110 VDC | -       |     |  |         |       |           |         |       |  |         |       |      |         |       |  |         |       |   |     |         |     |  |         |     |           |         |     |  |         |     |      |         |   |  |         |   |  |     |         |       |  |         |     |           |         |       |  |         |       |      |         |   |  |         |   |
|   | 220 VDC | -       |     |  |         |       |           |         |       |  |         |       |      |         |       |  |         |       |   |     |         |     |  |         |     |           |         |     |  |         |     |      |         |   |  |         |   |  |     |         |       |  |         |     |           |         |       |  |         |       |      |         |   |  |         |   |
| TDE4N-BY  |         |         |     |  |         |       |           |         |       |  |         |       |      |         |       |  |         |       |   |     |         |     |  |         |     |           |         |     |  |         |     |      |         |   |  |         |   |  |     |         |       |  |         |     |           |         |       |  |         |       |      |         |   |  |         |   |
| <ul style="list-style-type: none"> <li>• 2 C/O contacts</li> <li>• Double make double break</li> <li>• Magnetic arc blow out</li> <li>• Contact gap: 1.4 mm</li> </ul> <p><b>Breaking capacity</b></p> <table> <tr> <td>DC1</td> <td>110 VDC</td> <td>8 A</td> </tr> <tr> <td></td> <td>220 VDC</td> <td>4 A</td> </tr> <tr> <td>L/R=40 ms</td> <td>110 VDC</td> <td>5 A</td> </tr> <tr> <td></td> <td>220 VDC</td> <td>2 A</td> </tr> <tr> <td>DC13</td> <td>110 VDC</td> <td>1.5 A</td> </tr> <tr> <td></td> <td>220 VDC</td> <td>0.5 A</td> </tr> </table> | DC1     | 110 VDC | 8 A |  | 220 VDC | 4 A   | L/R=40 ms | 110 VDC | 5 A   |  | 220 VDC | 2 A   | DC13 | 110 VDC | 1.5 A |  | 220 VDC | 0.5 A |   |     |         |     |  |         |     |           |         |     |  |         |     |      |         |   |  |         |   |  |     |         |       |  |         |     |           |         |       |  |         |       |      |         |   |  |         |   |
| DC1   | 110 VDC | 8 A     |     |  |         |       |           |         |       |  |         |       |      |         |       |  |         |       |   |     |         |     |  |         |     |           |         |     |  |         |     |      |         |   |  |         |   |  |     |         |       |  |         |     |           |         |       |  |         |       |      |         |   |  |         |   |
|   | 220 VDC | 4 A     |     |  |         |       |           |         |       |  |         |       |      |         |       |  |         |       |   |     |         |     |  |         |     |           |         |     |  |         |     |      |         |   |  |         |   |  |     |         |       |  |         |     |           |         |       |  |         |       |      |         |   |  |         |   |
| L/R=40 ms   | 110 VDC | 5 A     |     |  |         |       |           |         |       |  |         |       |      |         |       |  |         |       |   |     |         |     |  |         |     |           |         |     |  |         |     |      |         |   |  |         |   |  |     |         |       |  |         |     |           |         |       |  |         |       |      |         |   |  |         |   |
|   | 220 VDC | 2 A     |     |  |         |       |           |         |       |  |         |       |      |         |       |  |         |       |   |     |         |     |  |         |     |           |         |     |  |         |     |      |         |   |  |         |   |  |     |         |       |  |         |     |           |         |       |  |         |       |      |         |   |  |         |   |
| DC13  | 110 VDC | 1.5 A   |     |  |         |       |           |         |       |  |         |       |      |         |       |  |         |       |   |     |         |     |  |         |     |           |         |     |  |         |     |      |         |   |  |         |   |  |     |         |       |  |         |     |           |         |       |  |         |       |      |         |   |  |         |   |
|   | 220 VDC | 0.5 A   |     |  |         |       |           |         |       |  |         |       |      |         |       |  |         |       |   |     |         |     |  |         |     |           |         |     |  |         |     |      |         |   |  |         |   |  |     |         |       |  |         |     |           |         |       |  |         |       |      |         |   |  |         |   |

## Timer relay TDE4N

### Mounting possibilities/sockets



#### Surface/wall mounting

|           |       |   |
|-----------|-------|---|
| 338000302 | V22BR | Screw socket, wall mount, front connection (9 mm terminals)                   |
| 338000580 | V23   | Screw socket, wall mount, front connection (7.5 mm terminals)                 |
| 338000610 | V29   | Spring clamp socket, wall mount, front dual connection (2.5 mm <sup>2</sup> ) |

#### Rail mounting

|           |       |   |
|-----------|-------|---|
| 338000580 | V23   | Screw socket, rail mount, front connection (7.5 mm terminals)                 |
| 338000402 | V23BR | Screw socket, rail mount, front connection (9 mm terminals)                   |
| 338000610 | V29   | Spring clamp socket, rail mount, front dual connection (2.5 mm <sup>2</sup> ) |

#### Panel/flush mounting

|           |     |   |
|-----------|-----|---|
| 338100100 | V3  | Solder tag socket, panel mount, rear connection                               |
| 328400100 | V26 | Crimp contact socket, panel mount, rear connection, A260 crimp contact        |
| 338000560 | V31 | Faston connection socket, rear dual connection (4.8 x 0.8 mm)                 |
| 338000670 | V33 | Spring clamp socket, flush mount, rear dual connection (2.5 mm <sup>2</sup> ) |

#### PCB mounting

|           |     |                      |
|-----------|-----|----------------------|
| 338000561 | V32 | PCB soldering socket |
|-----------|-----|----------------------|

No external retaining clip needed as the 'snap-lock' will hold the relay into the socket under all circumstances and mounting directions (according shock & vibration requirements IEC 61373, Category I, Class B, Body mounted). If regulations require external retaining clips, these are available as well.

For more details see datasheets of the sockets on [www.morssmitt.com](http://www.morssmitt.com)



## Timer relay TDE4N

### Mechanical keying relay and socket (optional)

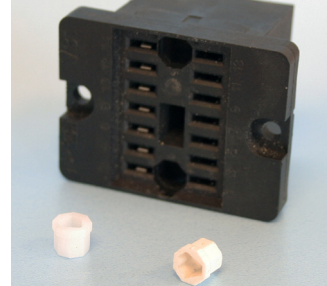

**Function:**

- To prevent wrong installation
- To prevent damage to equipment
- To prevent unsafe situations

Using keyed relays and sockets prevents a relay is inserted in a wrong socket. For example it prevents that a 24 VDC relay is put in a 110 VDC circuit. Positive discrimination is possible per different function, coil voltage, timing, monitoring, safety and non-safety.

The D relay socket keying option gives  $8 \times 8 = 64$  possibilities. Upon ordering the customer simply indicates the need for the optional keying. Mors Smitt will assign a code to the relay and fix the pins into the relay. The sockets are supplied with loose key receptacles. Inserting the keys into the socket is very simple and self explaining.

Remark: Sockets and relay shown are examples.

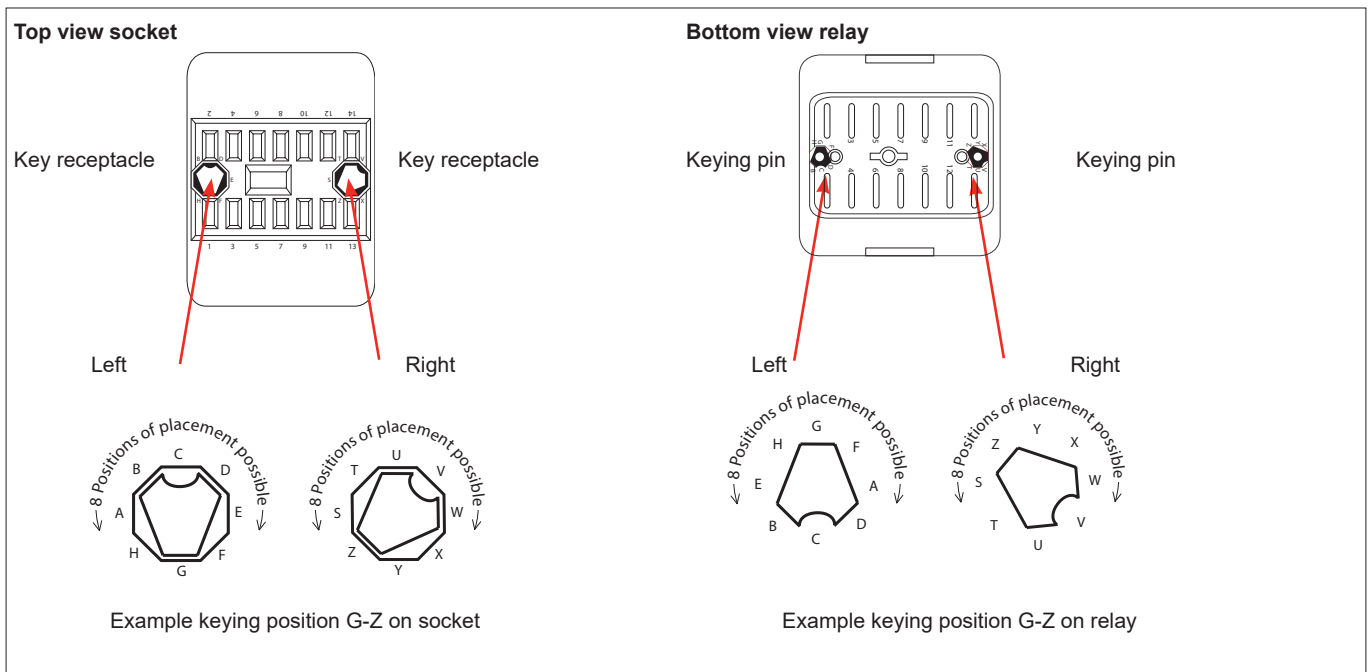

### Keying codes

|                             | Coil voltage code |        |
|-----------------------------|-------------------|--------|
|                             | 24-60             | 72-230 |
| Silver contacts (standard)  | AS                | AU     |
| Gold contacts (option E)    | DT                | AZ     |
| Silver tin oxide (option M) | GT                | GV     |

## Timer relay TDE4N

### Important for relay selection and operation

Make sure the relay is suitable for the application. For critical applications (for example: green loop applications) relays should be checked on correct working during periodic inspection.

### Recommendations for long time contact reliability

For relays to enable failure free performance over a very long operational time, it is important to create the right circumstances. In any relay, contact usage and atmospheric conditions influence the contact surface. To counter this effect it is common practice to use a safety factor of  $> 2$  to ensure long time contact reliability.

Therefore for long time contact reliability we recommend:

- Silver contacts: a minimum contact current of 20 mA per contact
- Gold contacts: a minimum contact current of 10 mA per contact
- Double Make Double Break contacts: a minimum contact current of 40 mA per contact
- When low currents are switched and not frequently, e.g. 10 mA once a day, it is advised next to gold plated contacts to put similar contacts within the same relay in parallel
- With higher load switching, e.g. 110 VDC and  $> 1$  A, put relay contacts in series
- Rule of thumb: any relay works best with switching currents  $> 20$  mA in DC environment when frequently switched. When not switched frequently a higher switching current like 50 mA is better for a long reliable operational time
- Check relays regularly, for example with the Mors Smitt Portable Relay Tester and visually through the transparent cover

### Instructions for use

#### Installation

Before installation or working on the relay: disconnect the power supply first (no hot swapping)! Install socket and connect wiring according to the terminal identification. Plug relay into the socket ensuring there is no gap between the bottom of relay and the socket. Reverse installation into the socket is not possible due to the mechanical blocking snap-lock feature. Check to ensure that the coil connection polarity is not reversed. Relays can be mounted tightly together to save space. When rail mounting is used, always mount the socket in the direction of the UP arrow, to have proper fixation of the socket on the rail.

#### Warning!

- Never use silicon in the proximity of the relays
- Do not use the relay in the presense of flammable gas as the arc generated from switching could cause ignition
- To remove relays from the socket, employ up and down lever movements. Sideway movement may cause damage to the coil wires

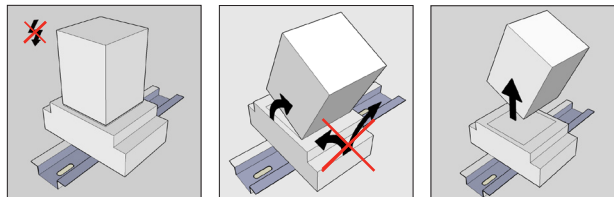

- Relays should never be swapped to other circuit positions when taken out of its socket for inspection or fault finding, always place it back into the original position to prevent contact resistance problems. Contact resistance problems can be created when swapping relays between different circuit loads due the contact wear/condition having changed during its operational life.

#### Operation

After installation always apply the rated voltage to the coil to check correct operation. Long term storage may corrode the silver on the relay pins. When plugging the relay into the socket, the female bifurcated or trifurcated receivers will automatically cut through the corrosion on the pins and guarantee a reliable connection.

Before actual use of relays, it is advised to switch the load several times with the contacts. The contacts will both be electrically and mechanically cleaned due to the positive wiping action. Sometimes a contact can build up increased contact resistance ( $\leq 15$  m $\Omega$  when new). When using silver contacts one can clean the contact by switching a contact load a few times using  $>24$  VDC &  $\sim 2$  A. Increased contact resistance is not always problematic, as it depends on circuit conditions. In general a contact resistance of 1  $\Omega$  is no problem, consult Mors Smitt for more information.

Condensation in the relay is possible when the coil is energised (warm) and the outside, environmental temperature is cold. This is a normal phenomenon and will not affect the function of the relay. Materials in the relay have no hygroscopic properties.

## Timer relay **TDE4N**

### Inspection / maintenance

Correct operation of the relay can easily be checked as the transparent cover provides good visibility of the moving contacts. If the relay does not seem to operate correctly, check for presence of the appropriate coil voltage and polarity using a suitable multimeter. If a LED is fitted, it indicates voltage presence to the coil. If coil voltage is present, but the relay does not operate, a short circuit of the suppression diode is possible (This may have been reversed due to the coil connection).

Relays can easily be tested with the Mors Smitt Relay Tester. More information on: [www.morssmitt.com](http://www.morssmitt.com).

If the relay doesn't work after inspection, replace the relay unit with a similar model. Do not attempt to open the relay cover or try to repair. Contacts are calibrated and in balance, touching can affect proper operation. Also resoldering may affect correct operation. Since 2009 relays have tamper proof seals fitted and once broken, warranty is void.

Most relay defects are caused by installation faults such as overvoltage, spikes/transients, high/short current far exceeding the relay specifications. When returning the relays for investigation, please provide all information on the RMA form. Send defective relays back to the manufacturer for repair or replacement. Normal wear and tear or external causes are excluded from warranty.

RMA procedure see [www.morssmitt.com](http://www.morssmitt.com)

## Timer relay TDE4N

### Ordering scheme

| TDE4N   |                |   |           | code |  |  |  |
|---|----------------|---|-----------|------|--|--|--|
| Coil voltages                                   | 24-60 V AC/DC  |   |           |      |  |  | Cannot be combined with                        |
|   | 72-250 V AC/DC |   |           |      |  |  |  |
| Options<br>(add as many options as needed)      |                | B |           |      |  | Magnetic arc blow-out                                    |  |
|   |                | C |           |      |  | Low temperature (-40 °C) - Max contact current 8 A       |  |
|   |                | E |           |      |  | Gold plated contacts                                     | M  |
|   |                | K |           |      |  | Extra dust protection, IP50                              |  |
| Special options<br>(minimum order quantity: 20) |                | Y |           |      |  | Double make / double break contacts                      |  |
|   |                | M |           |      |  | AgSnO <sub>2</sub> contacts, highly resistant to welding | E  |
| Time ranges                                     |                |   | 0 - 1 s   |      |  |  |  |
|   |                |   | 0 - 3 s   |      |  |  |  |
|   |                |   | 0 - 6 s   |      |  |  |  |
|   |                |   | 0 - 10 s  |      |  |  |  |
|   |                |   | 0 - 30 s  |      |  |  |  |
|   |                |   | 0 - 60 s  |      |  |  |  |
|   |                |   | 0 - 100 s |      |  |  |  |
|   |                |   | 0 - 180 s |      |  |  |  |
|   |                |   | Fixed     |      |  | Value between 0-180 s, no knob                           |  |
| Keying code                                     |                |   |           |      |  |  | See table on page 9, leave blank for no keying |

Example: TDE4N 72-250 V AC/DC CE 0-10 s

Description: TDE4N relay, Unom: 72-250 V AC/DC, gold plated contacts, low temperature (-40 °C), adjustable delay time 0-10 s, no keying code

Example: TDE4N 24-60 V AC/DC Y 120 s AS

Description: TDE4N relay, Unom: 24-60 V AC/DC, double make / double break contacts, fixed time delay time 120 s, keying code AS

Timer relay  
**TDE4N**

---

 **Over 10 million Mors Smitt relays in use in applications worldwide!**

**Mors Smitt Asia Ltd.**  
26/F., Casey Aberdeen House  
38 Heung Yip Road, Wong Chuk Hang  
Hong Kong  
Tel: +852 2343 555  
sales.msa@wabtec.com

**Mors Smitt France SAS**  
2 Rue de la Mandinière  
72300 Sablé-sur-Sarthe, France  
Tel: +33 (0) 243 92 82 00  
sales.msf@wabtec.com

**Mors Smitt UK**  
Graycar Business Park  
Burton on Trent, DE13 8EN, UK  
Tel: +44 (0)1283 357 263  
sales.msuk@wabtec.com

**Wabtec Netherlands B.V.**  
Darwinstraat 10  
6718 XR Ede, Netherlands  
Tel: +31 (0)88 600 4500  
sales.msbv@wabtec.com

**Mors Smitt Technologies Ltd.**  
1010 Johnson Drive  
Buffalo Grove, IL 60089-6918, USA  
salesmst@wabtec.com

**RMS Mors Smitt**  
19 Southern Court  
Keysborough, VIC 3173, Australia  
Tel: +61 (0)3 8544 1200  
sales.rms@wabtec.com

(c) Copyright 2022

All rights reserved. Nothing from this edition may be multiplied, or made public in any form or manner, either electronically, mechanically, by photocopying, recording, or in any manner, without prior written consent from Mors Smitt. This also applies to accompanying drawings and diagrams. Due to a policy of continuous development Mors Smitt reserves the right to alter the equipment specification and description outlined in this datasheet without prior notice and no part of this publication shall be deemed to be part of any contract for the equipment unless specifically referred to as an inclusion within such contract. Mors Smitt does not warrant that any of the information contained herein is complete, accurate, free from potential errors, or fit for any particular purpose. Mors Smitt does not accept any responsibility arising from any party's use of the information in this document.